

# Elliptical Bike

# **XFIT** SPACER

## User's Manual

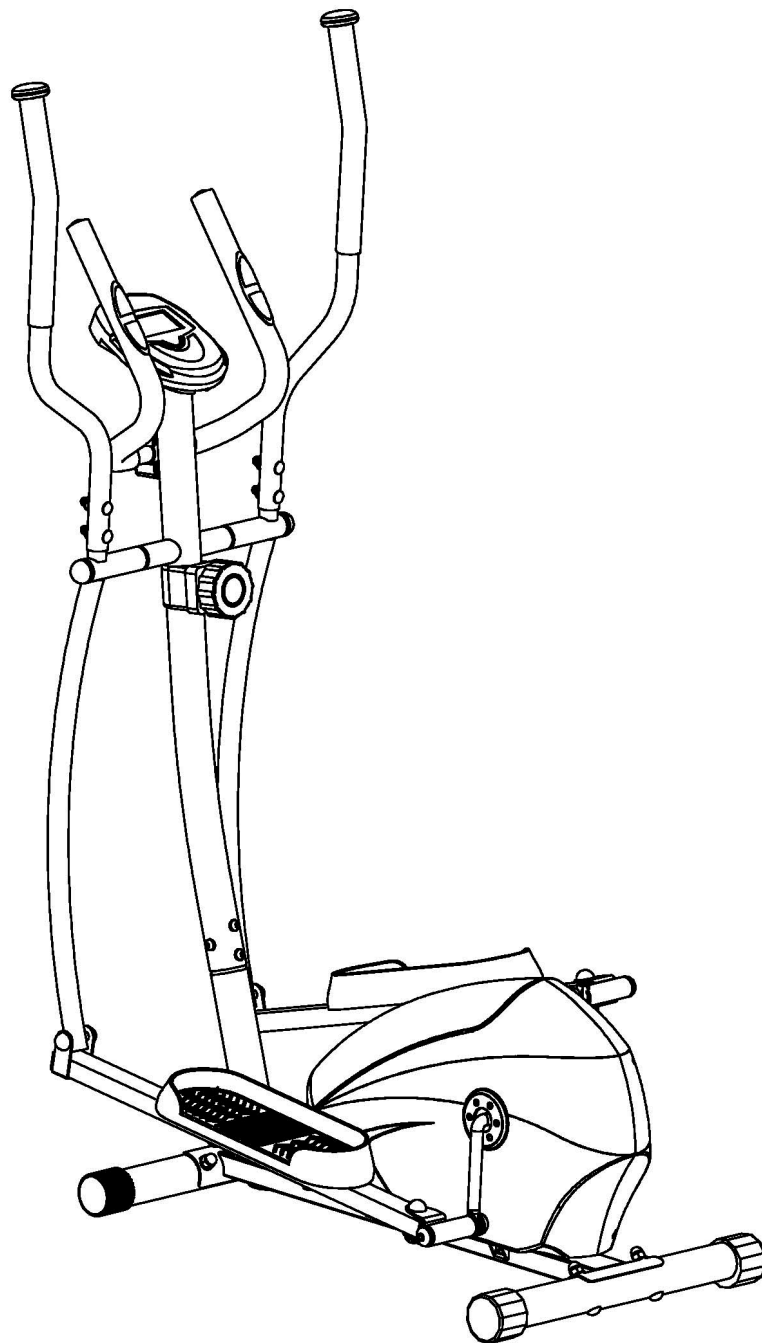

\* The specifications of this product may vary slightly from the illustrations and are subject to change without notice.

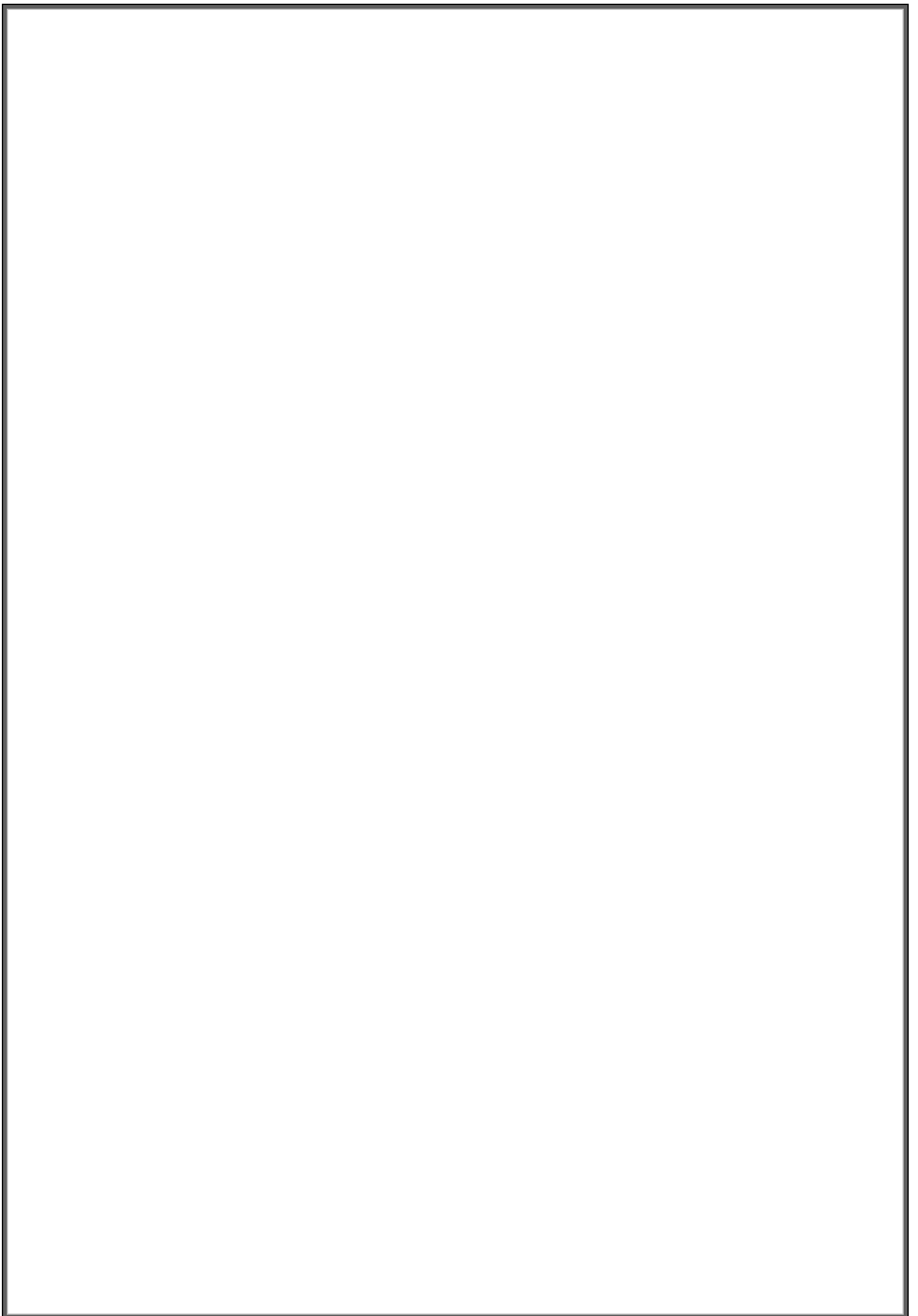

## IMPORTANT SAFETY NOTICE

Note the following precaution before assembling and operating the machine.

1. Assemble the machine exactly as the descriptions in the instruction manual.
2. Check all the bolts, nuts and other connections before using the machine for the first time to ensure the machine is in the safe condition.
3. Set up the machine in a dry level place and keep it away from moisture and water.
4. Place a suitable base (e.g. rubber mat, wooden board etc.) beneath the machine in the area of assembly to avoid dirt.
5. Before beginning the training, remove all objects within a radius of 2 meters from the machine.
6. Do not use aggressive cleaning articles to clean the machine. Only use the supplied tools or suitable tools of your own to assemble the machine or repair any parts of machine. Remove drops of sweat from the machine immediately after finishing training.
7. Your health can be affected by incorrect or excessive training. Consult a doctor before beginning the training program. He can define the maximum setting (Pulse, Watts, Duration of training etc) to which you may train yourself and can get precise information during training. This machine is not suitable for therapeutic purpose.
8. Only do training on the machine when it is in correct working way. Use only original spare parts for any necessary repairs.
9. This machine can be used for only one person's training at a time.
10. Wear training clothes and shoes that are suitable for fitness training with the machine. Your training shoes should be appropriate for the trainer.
11. If you have a feeling of dizziness, sickness or other abnormal symptoms, please stop training and consult a doctor immediately.
12. People such as children and handicapped persons should only use the machine in the presence of another person who can give aid and advice.
13. The power of the machine increases with increasing the speed, and the reverse. The machine is equipped with adjustable knob that can adjust the resistance.

**CAUTION!** The company does not have no responsibility for causing damage due to misuse of the product and non-compliance with the instructions for use.

**THE WARRANTY IS NOT VALID IF:** The machine is placed outdoors or exposed to sun and dust.

# EXPLODED DIAGRAM

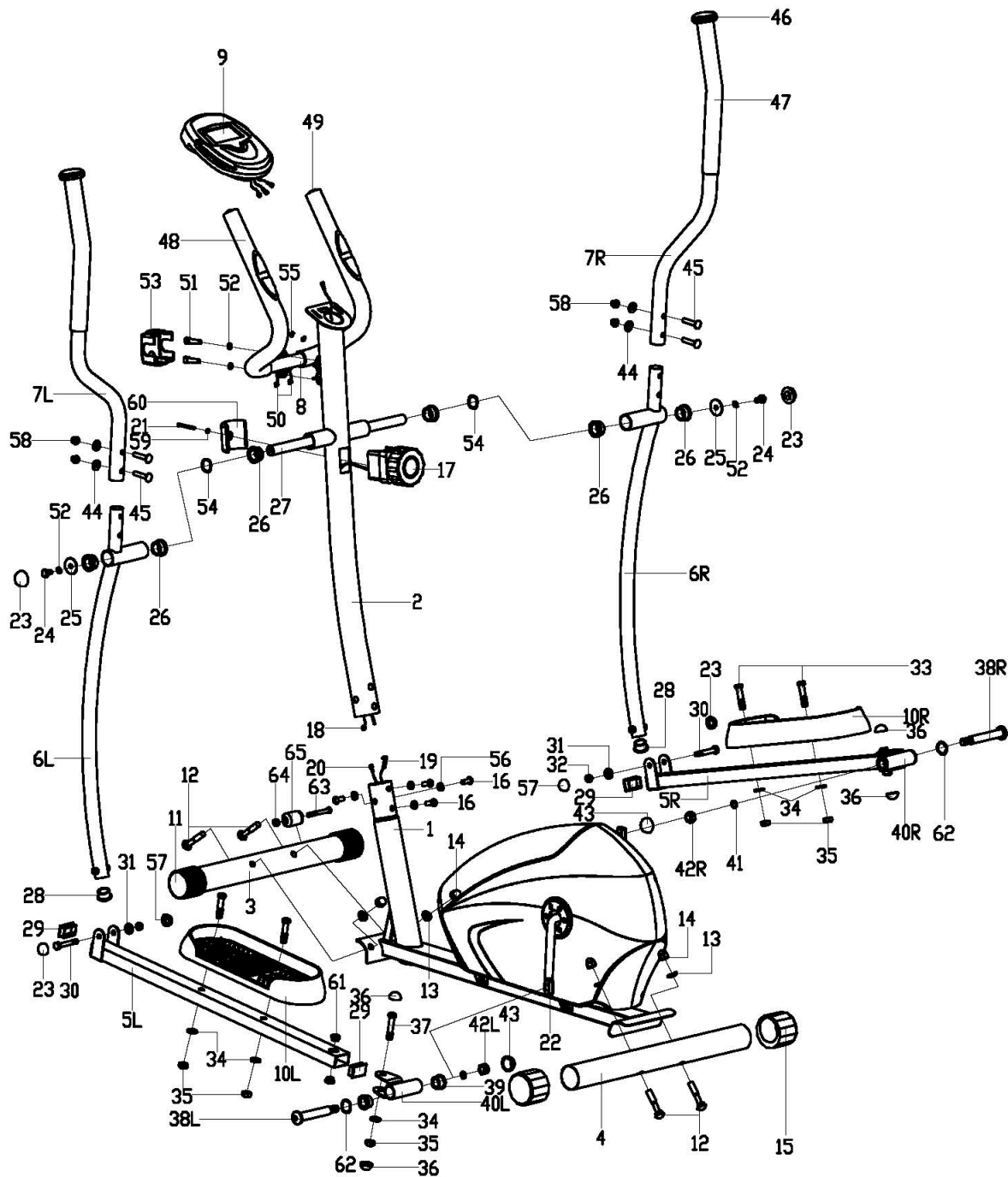

## PARTS LIST

NO.	DESCRIPTION	QTY	NO.	DESCRIPTION	QTY
1	Main frame	1	34	Flat washer d10X1.5	6
2	Handlebar post	1	35	Nylon nut M10	6
3	Front stabilizer	1	36	Nut cap S16	4
4	Rear stabilizer	1	37	Hex bolt M10X50	2
5 L/R	Pedal support (L/R)	1pr.	38 L/R	Pedal locking bolt (L/R)	1pr.
6 L/R	Swing bar(L/R)	1pr.	39	Axle bushing $\Phi$ 24 X20X $\Phi$ 16.1	4
7 L/R	Handlebar (L/R)	1pr.	40 L/R	Connecting joint (L/R)	1pr.
8	Armrest	1	41	Spring washer $\Phi$ 13 XB2	2
9	Computer	1	42 L/R	Nylon nut (L/R)	1pr.
10 L/R	Pedal (L/R)	1pr.	43	Nut cap S19	2
11	Front end cap	2	44	Arc washer $\Phi$ 20 Xd8X2XR16	4
12	Carriage bolt M10X57	4	45	Carriage bolt M8X40	4
13	Arc washer $\Phi$ 10 X1.5X $\Phi$ 25XR28	4	46	Mushroom end cap	2
14	Acorn nut M10	4	47	Handlebar foam grip	2
15	Rear end cap	2	48	Armrest foam grip	2
16	Allen screw M8X16	4	49	Round end cap $\Phi$ 25X1.5	2
17	Tension controller	1	50	Pulse sensor wire	2
18	Extension wire	1	51	Hex bolt M8X30	2
19	Tension cable	1	52	Spring washer D8	4
20	Sensor wire	1	53	Handlebar chuck cover	1
21	Cross screw M5X45	1	54	Waveform washer $\Phi$ 20X $\Phi$ 28 X0.3	2
22	Crank	1	55	Cross screw M4X12	2
23	Nut cap S14	4	56	Arc washer $\Phi$ 20Xd8.5XR25	4
24	Hex bolt M8X15	2	57	Nut cap S13	2
25	Flat washer $\Phi$ 8.2X $\Phi$ 32 X2	2	58	Acorn nut M8	4
26	Axle bushing $\Phi$ 32 X2.5	6	59	Flat washer D5	1
27	Long axle	1	60	Tension controller cover	1
28	Round end cap $\Phi$ 28 X1.5	2	61	Metal bushing $\Phi$ 14X10X $\Phi$ 10.1	4
29	Square end cap 40X25X1.5	4	62	Waveform washer D17X0.3	2
30	Hex bolt M8X55	2	63	Hex bolt M6X45	2
31	Flat washer d8 X1.5	2	64	Nylon nut M6	2
32	Nylon nut M8	2	65	Roller	2
33	Hex bolt M10X45	4			

**Note:** Most of the listed assembly hardware has been packaged separately, but some hardware items have been preinstalled in the identified assembly parts. In these instances, simply remove and reinstall the hardware as assembly is required.

Please reference the individual assembly steps and make note of all preinstalled hardware.

**PREPARATION:** Before assembling, make sure that you will have enough space around the item; Use the present tooling for assembling; Before assembling please check whether all needed parts are available.

It is strongly recommended this machine to be assembled by two or more people to avoid possible injury.

# EXERCISE COMPUTER INSTRUCTION MANUAL

No. 00169

## FUNCTIONAL BUTTONS:

MODE – Press it to select functions.

– Hold it for 3 seconds to reset time, distance and calories.

SET (IF HAVE) – To set value of time, distance and calories when not in scan mode.

RESET (IF HAVE) – Press to reset time, distance and calories.

## FUNCTIONS:

1. SCAN: Press MODE button until “▼” appears at SCAN Position (or until “SCAN” appears), computer will rotate through all the 5 functions: Time, Speed, Distance, Calorie and total distance. Each display will be hold for 4 seconds.
2. TIME: Count the total time from exercise start to end.
3. SPEED: Display current speed.
4. DIST : Count the distance from exercise start to end.
5. CALORIES(CAL): Count the total calories from exercise start to the end.
6. TOTAL DIST(ODO): Count the total distance after installing the batteries.
7. AUTO ON/OFF & AUTO START/STOP: Without any signal for 8 minutes, the power will turn off automatically. As long as the wheel is in motion or press any button, the computer is in action.
8. PULSE RATE (IF HAVE)  
Press MODE button until “▼” appears at PULSE position(or until “♥” appears). Before measuring your pulse rate, please place both your palms on the contact pads and the computer will show your current heart beat rate in beats per minute (BPM) on the LCD after 3~4 seconds.  
Remark: During the process of pulse measurement, because of the contact jamming, the measurement value may be higher than virtual pulse rate during the first 2~3 seconds, then it will return to normal level. To ensure testing accuracy, it is suggested that user test pulse during stop/pause exercise to avoid any possible influence. The measurement value can not be regarded as the basis of medical treatment.
9. ALARM  
The functions of time, distance and calorie can be set countdown, any of above value goes to zero, the computer will alarm for 15 seconds.  
Press MODE to select the function, then press SET to adjust the value.

**Note:** ● The product with only “MODE” button has no No.9 function.

- The computer can be programmed before delivery with Metric or Imperial system. If you find “M” in right side of monitor screen, it is with Imperial system and the unit will be mile.

## SPECIFICATIONS

FUNCTION	Auto Scan	Every 4 seconds
	Running Time	00:00 ~ 99:59(Minute: Second)
	Current Speed	The max pick-up signal is 99.9KM/H or MILE/H (or 1500RPM)
	Trip Distance	0.00 ~ 99.99 KM or MILE
	Calories	0 ~ 999.9~ 9999 Kcal
	Total Distance	0 ~ 9999 KM or MILE
	Pulse Rate (IF HAVE)	40-240BPM
Battery Type	2 pcs of SIZE-AAA or UM4	
Operating Temperature	0°C ~ +40°C(32°F~ 104°F)	
Storage Temperature	-10°C ~ +60°C(14°F~ 140°F)	

# ASSEMBLY INSTRUCTION

**Note: Assembly requires 2 people.**

## Step 1:

Fix the Front stabilizer (3) and Rear stabilizer (4) to the Main frame (1) with Carriage bolt (12), Arc washer (13) and Acorn nut (14)

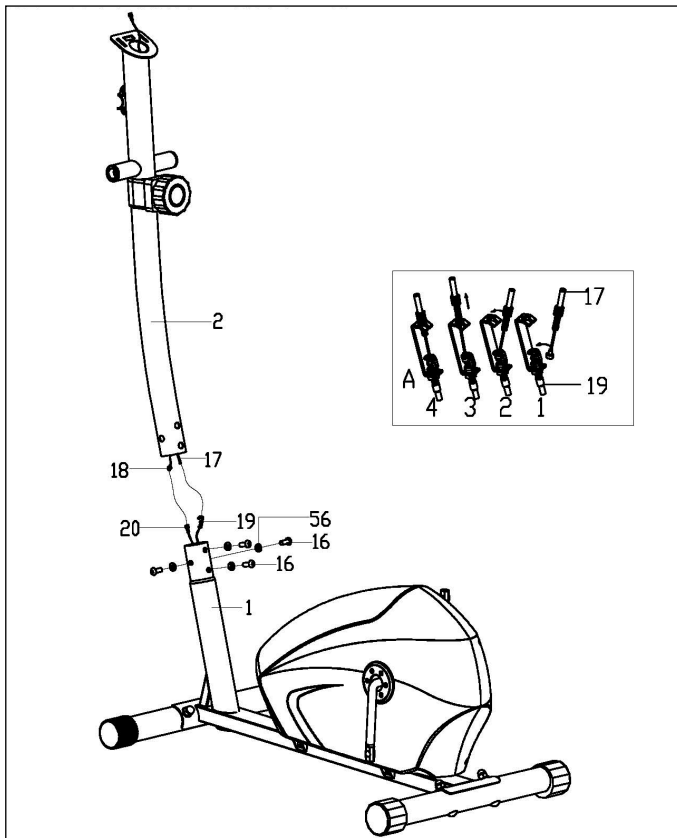
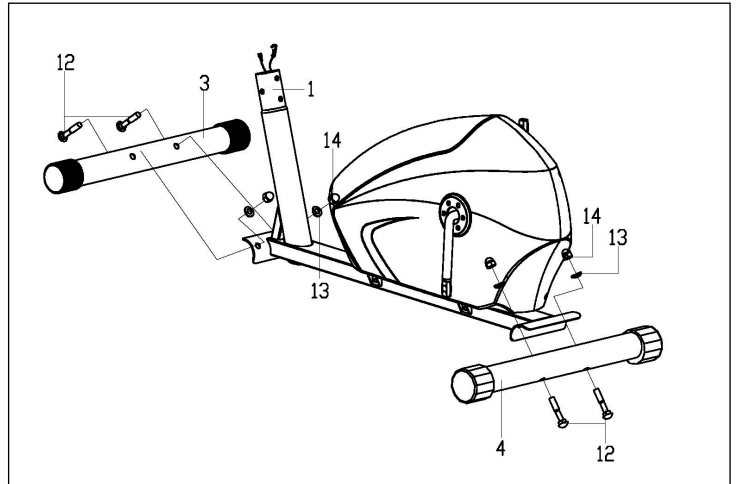

## Step 2:

Connect the Sensor wire (20) well with Extension wire (18) and then connect the Tension cable (19) well with wire of Tension controller (17) as shown.

Fix the Handlebar post (2) to the Main frame (1) with Allen screw (16), Spring washer (56).



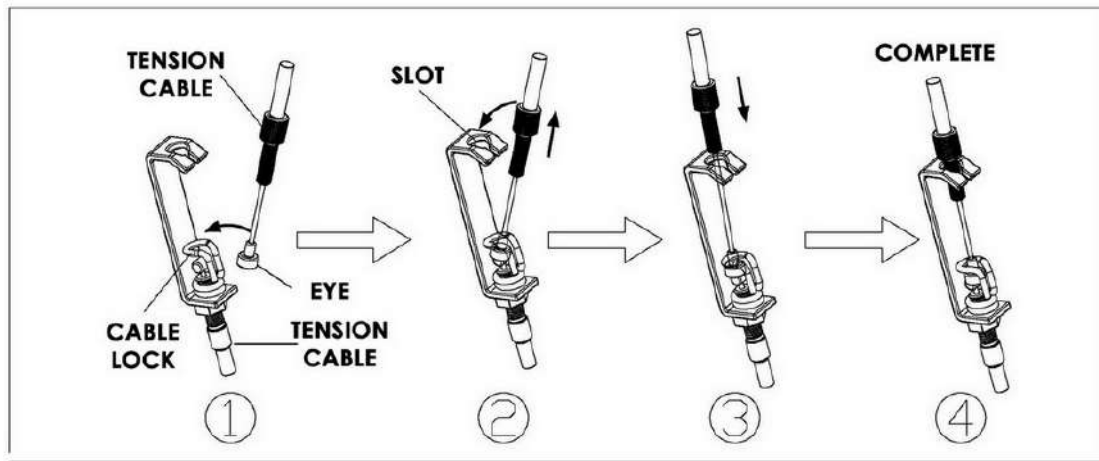

### Step 3:

- A:** Fix the Swing bar (6L) on the long axle of the Handlebar post (2) with Hex bolt (24), Spring washer (52), Flat washer (25), Waveform washer (54) and Long axle (27) as shown. Please do not tighten them this time.
- B:** Attach the connecting joint together with Pedal Support (5L) to the Crank (22) using Pedal support bolt (38L), Waveform washer (62), Spring washer (41) and Nylon nut (42L) as shown. Please do not tighten them this time.
- C:** Connect Swing bar (6L) with Pedal support (5L) using Hex bolt (30), Flat washer (31) and Nylon nut (32). Tighten the Hex bolt (24) (30) and Nylon nut (42L). Finally Cover the Nut caps (23) (57) (43) (36).
- D:** Fix the Pedal support (5R) and Swing bar (6R) to Crank (22) and Handlebar post (2) in the same way.
- E:** Fix the Pedal (10L/R) to the Pedal support (5L/R) with Hex bolt (33), Flat washer (34) and Nylon nut (35).

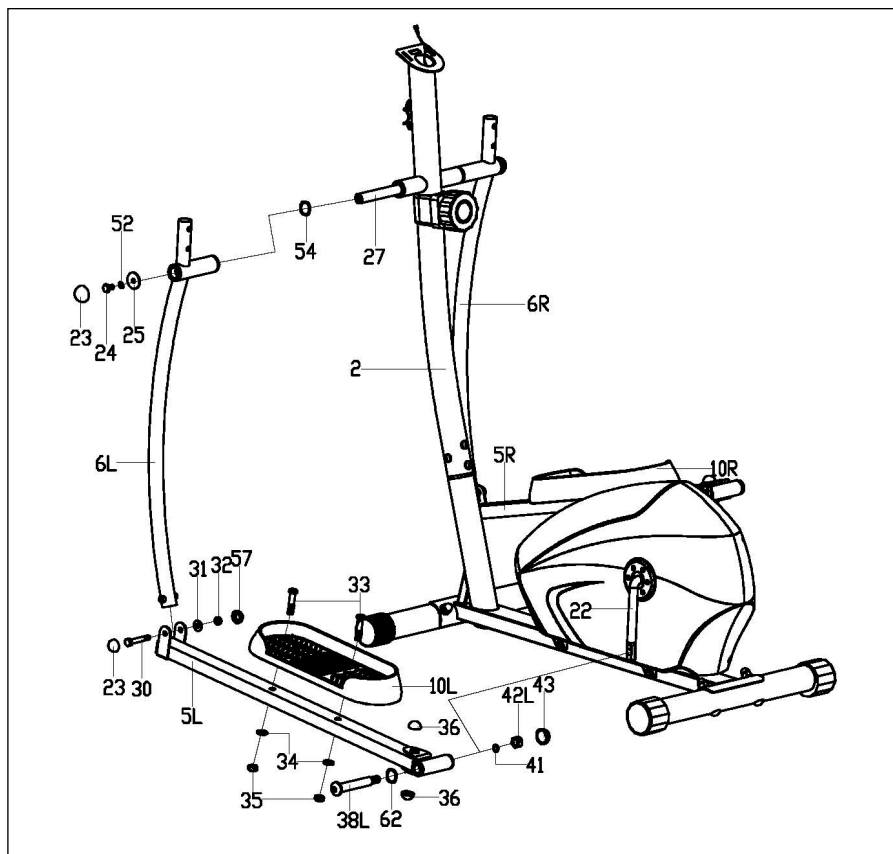

#### Step 4:

**A:** Put the Pulse sensor wire (50) through the handlebar post (2) and then out of the hole of the computer bracket. Fix the armrest (8) on the handlebar post (2) with Hex screw (51) and Spring washer (52) and then cover the Handlebar chuck cover (53) to the related position.

**B:** Attach the Handlebar (7L/R) to the Swing bar (6L/R) using Carriage bolt (45), Arc washer (44) and Acorn nut (58).

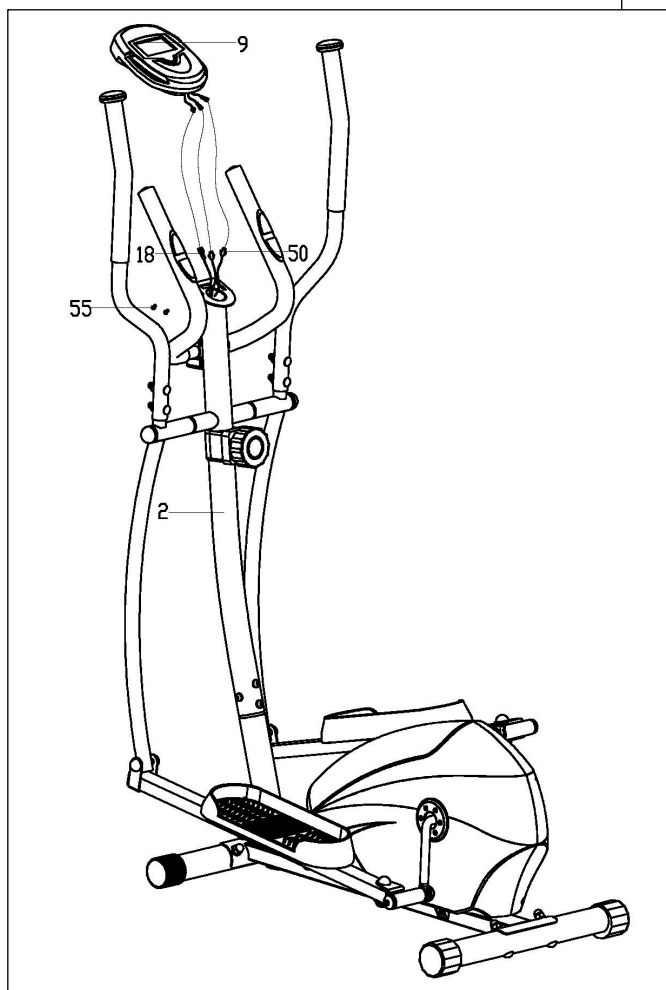
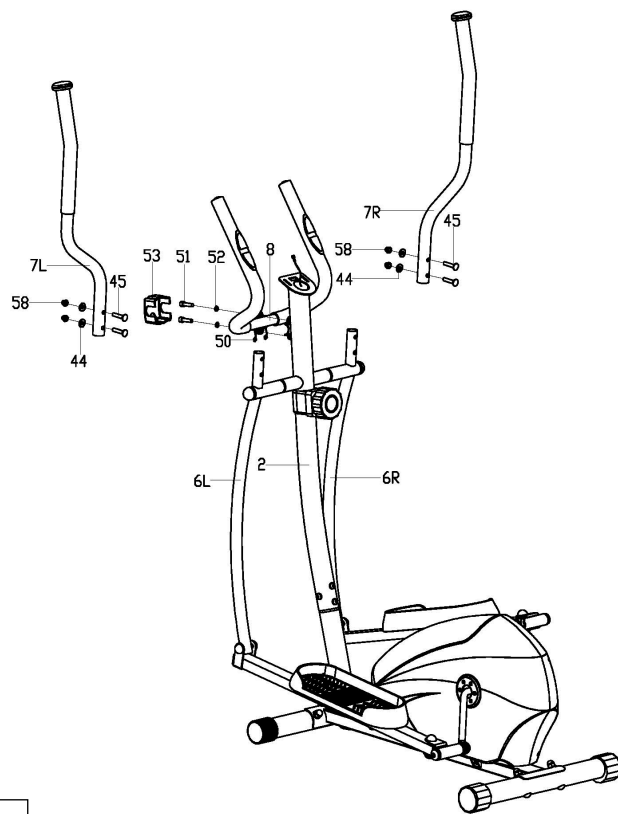

#### Step 5:

Connect the Pulse sensor wire (50) and Extension wire (18) with the wires coming from the computer (9), and then fix the computer (9) onto the computer bracket of the Handlebar post (2) with Cross screw (55).

**Check and tighten the screws at regular intervals, as they may loosen due to vibrations. Damage that may be caused by a lack of maintenance is not covered by the warranty.**

# WARM-UP EXERCISE

Using your bike will provide you with several benefits. It will improve your physical fitness, tone your muscles and in conjunction with a calorie-controlled diet, help you lose weight.

## WARM-UP PHASE

The purpose of warming up is to prepare your body for exercise and to minimize injuries. Warm up for two to five minutes before strength-training or aerobic exercising. Perform activities that raise your heart rate and warm the working muscles. Activities may include brisk walking, jogging, jumping jacks, jump rope, and running in place.

## STRETCHING

Stretching while your muscles are warm after a proper warm-up and again after your strength or aerobic training session is very important. Muscles stretch more easily at these times because of their elevated temperature, which greatly reduces the risk of injury. Stretches should be held for 15 to 30 seconds.

## DO NOT BOUNCE.

*Remember always to check with your physician before starting any exercise program.*

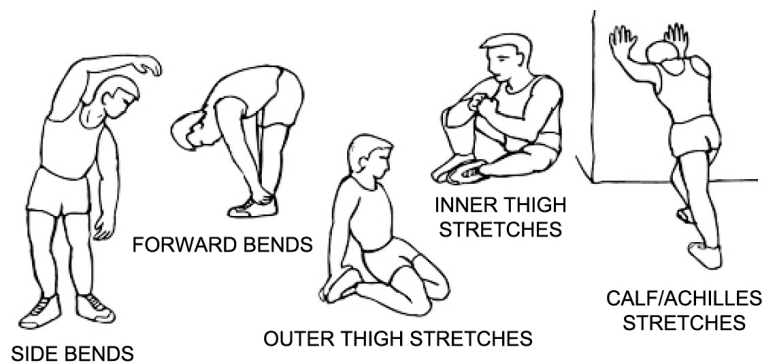

## EXERCISE PHASE

This is the stage where you put the effort in. After regular use, the muscles in your legs will become more flexible. Work at your own pace and be sure to maintain a steady tempo throughout. The rate of work should be sufficient to raise your heartbeat into the target zone shown on the graph below.

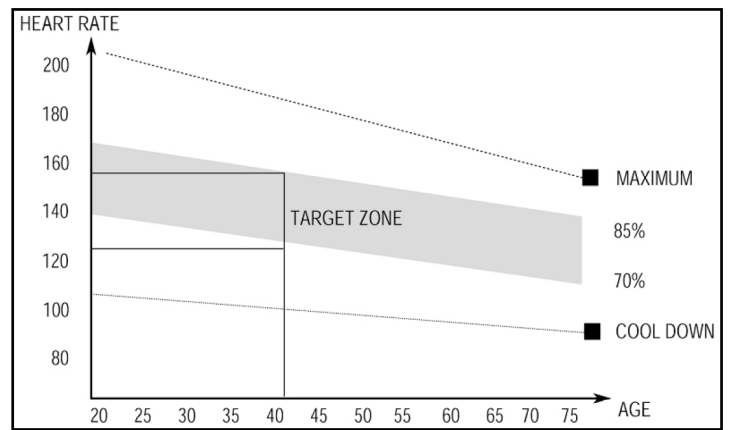

## COOL-DOWN PHASE

The purpose of cooling down is to return the body to its normal or near normal, resting state at the end of each exercise session. A proper cool-down slowly lowers your heart rate and allows blood to return to the heart.

### **TERMS OF WARRANTY**

- Warranty period is 1 year for mechanical, electrical / electronic parts and 5 years for the metal frame.
- X-TREME STORES S.A. undertakes to repair the machine free of charge in the event of damage due solely to a manufacturing fault. The warranty covers the cost of the spare parts. Replacement of spare parts or not is up to the company technicians. The customer is responsible for the control and adjustment of the machine.
- This warranty note is only valid if it is accompanied by legal proof of purchase (invoice or retail receipt). The warranty period is not extended for any reason and the transfer of it to a third party is excluded.
- Any damage is repaired as soon as possible and any claim for damages due to lack of spare parts and delay in repairing the damage is excluded. The costs of transporting the machine to or from the dealership will be borne by the customer after 6 months of purchase.
- The warranty conditions are set by the manufacturers of machinery and are governed by European regulations.
- Upon expiry of the warranty, any replacement part is covered by a 6-month warranty.

### **THE WARRANTY SHALL NOT APPLY:**

- When the machine is used for any purpose other than home use (gyms, clubs, institutes, hotels, studios, etc.).
- When the fault is the result of misuse, alterations, poor connection, poor maintenance, voltage fluctuations in the PPC network.
- Components damaged by user fault such as broken plastic parts, damage when moving the machine.
- Components such as side pads and cushions are considered consumables and are covered by a 6-month warranty.
- When the machine is opened or repaired by third parties.
- When the damage is caused by the buyer's negligence & the instructions for use have not been followed.
- When the machine is outdoors or exposed to sun or dust.
- When electronic components (console) are damaged by intense sweating or other liquid that has come into contact with or penetrated inside them.

**Tel.:** 210 66 20 921 -2 – **Fax:** 210 66 20 923 – **e-mail:** [service@xtr.gr](mailto:service@xtr.gr)

# Notes

A large rectangular area with a dotted border, containing 21 horizontal dotted lines for writing notes.

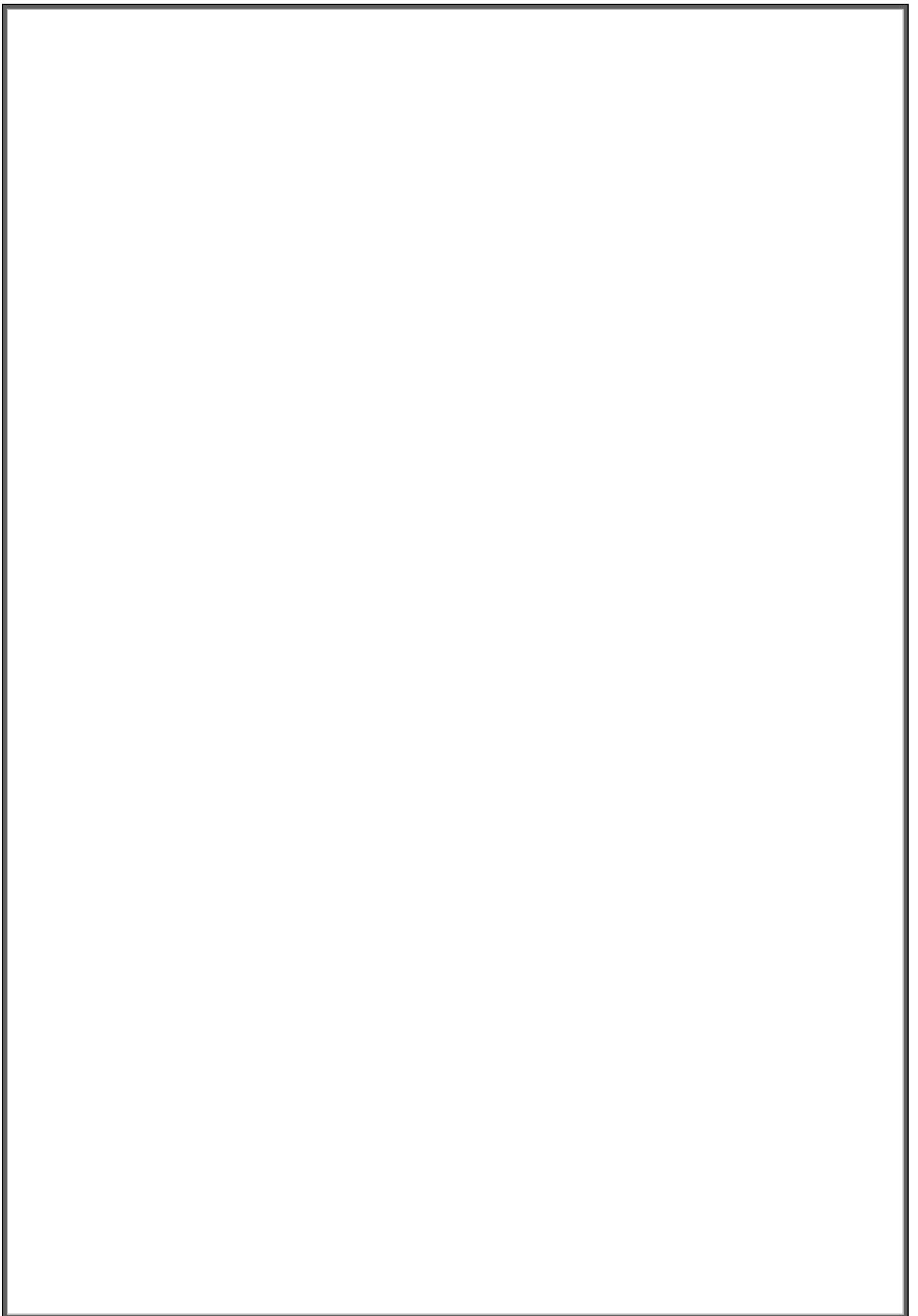



34 koupi Avenue, Koropi  
P.C.:19441 - P.O. Box 6201  
**Tel.:** 210 66 20 921 -2 - **Fax:** 210 66 20 923  
**E-mail:** [info@xtr.gr](mailto:info@xtr.gr) • [f/xtrstores](https://www.facebook.com/xtrstores) •  [@xtr.gr](https://www.instagram.com/xtrstores)

**Tel. for all of Greece:**  
801.11.15.100

**[www.xtr.gr](http://www.xtr.gr)**