

**Treadmill**

# **XFIT AIR**

**User's Manual**

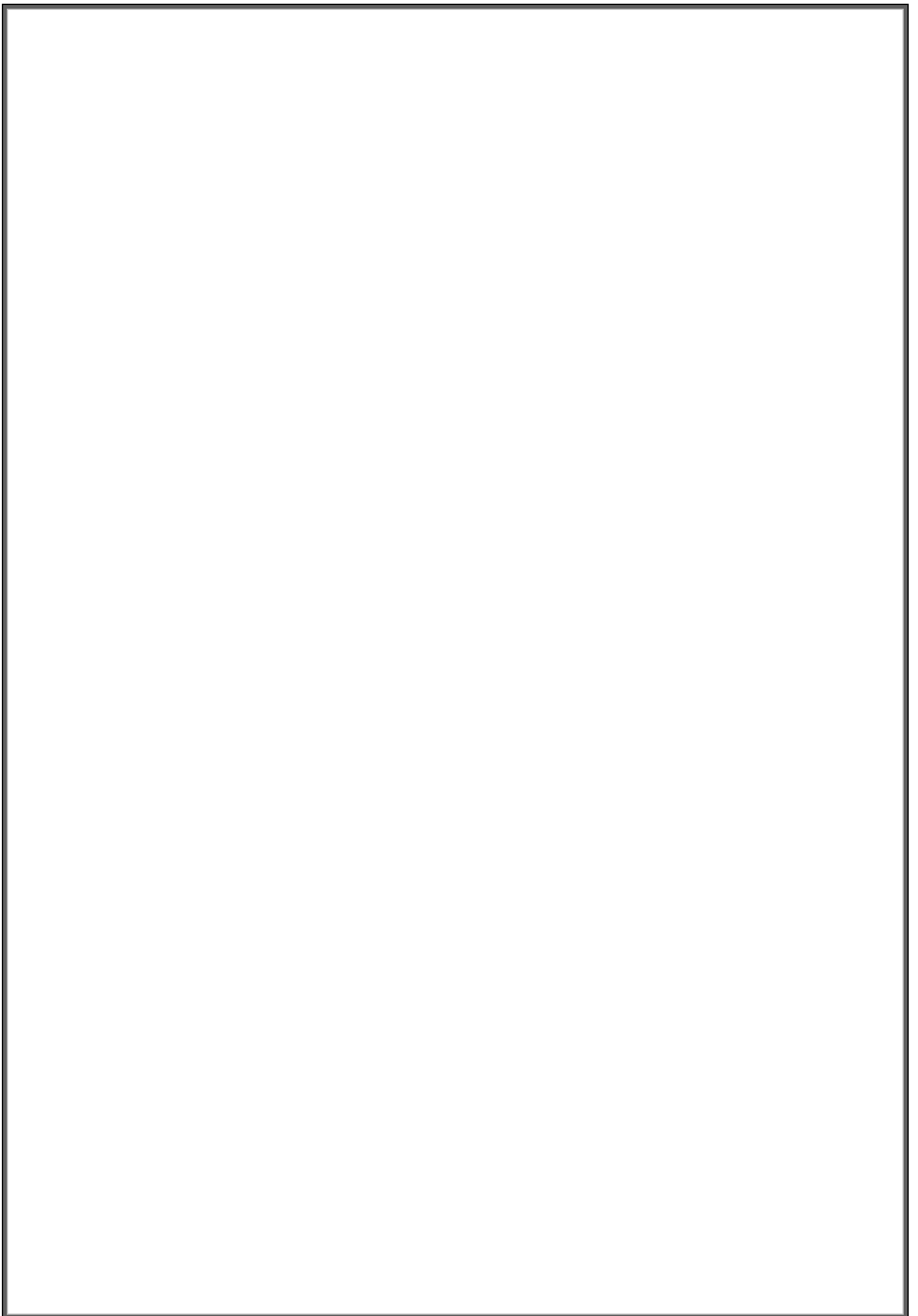



**CONTENTS**

Contents	1
Safety Caution	2-3
Assembly instruction	4-6
Operation guide	7-14
How to fold and move	15
Suggested stretches	16-17
Maintenance	18-19
Exploded drawing	20
Part list	21-22
Trouble Shooting	23

## SAFETY CAUTIONS

When using this product, basic precautions should always be followed, including the following:

Please read the instruction carefully before starting to use this product.

**Danger** – To reduce the risk of electric shock:

1. Always unplug this product from the electrical outlet immediately after using and before cleaning.

**Warning** – To reduce the risk of burns, fire, electric shock, or physical injury:

1. The product should never be left unattended while plugged in. Unplug the product from the outlet when not in use.
2. Close supervision is necessary when this product is used by or near children, invalids, or disabled persons.
3. Be sure to use the product only for its intended use as described in this manual. Do not use any attachment not recommended by the manufacturer in order to avoid any danger or accidents.
4. Never operate the product if it has a damaged cord or plug, if it is not working properly, if it has been damaged, or dropped into water. Please return the product to the service center of seller for examination and repair.
5. Do not carry this product by the supply cord or use the cord as a handle.
6. Keep the cord away from hot surfaces or ground.
7. Never operate the product with the air vents blocked. Keep the air vents free of lint, hair, etc.
8. Never drop or insert any objects into any openings.
9. Do not use or operate outdoors.
10. Do not operate where aerosol (spray) products are being used or where oxygen is thin.
11. Before turning the product power off, turn all controls to the off position then remove the plug from the outlet.
12. Connect the product to a properly grounded outlet only.
13. If the treadmill is foldable, when user finishes using the treadmill, the elevation needs to be back to original position.
14. When user is using the treadmill, it cannot be folded at the same time.
15. Keep a safety zone of 2000mm x 1000mm away from the treadmill.
16. This machine is only intended for household use.
17. For the treadmill with folding function and electric elevation, be sure that the elevation is 0 before folding (To avoid interference of the components).
18. Stop using the treadmill if you feel faint, dizzy, or short of breath.
19. Wear appropriate exercise clothes when using the treadmill. Do not wear loose clothes that could become caught in the treadmill. Athletic support clothes are recommended for both men and women. Always wear athletic shoes. Never use the treadmill with bare feet, wearing only stockings, or in sandals.

**CAUTION!** The company does not have no responsibility for causing damage due to misuse of the product and non-compliance with the instructions for use.

## SAFETY CAUTIONS

### GROUNDING INSTRUCTIONS

The products must be grounded first. If malfunction or breakdown occurs, grounding will provide a path of least resistance for electric current to reduce the risk of electric shock.

The product is equipped with a cord having an equipment-grounding conductor and a grounding plug. The plug must be plugged into an appropriate outlet that is properly installed and grounded in accordance with all local codes and ordinances.

**Danger** – Improper connection of the equipment-grounding conductor can result in a risk of electric shock. Check with a qualified electrician or serviceman if you are in doubt as to whether the products are properly grounded. Do not modify the plug provided with the product – if it will not fit the outlet, have a proper outlet install by a qualified electrician.

The products is for use on nominal 220-240 volt and has a grounding plug that looks like the plug illustrated in the figure . Make sure that the product is connected to an outlet having the same configuration as the plug.

There is no need to use any adapter for this product.

**Figure**  
**Grounding methods**

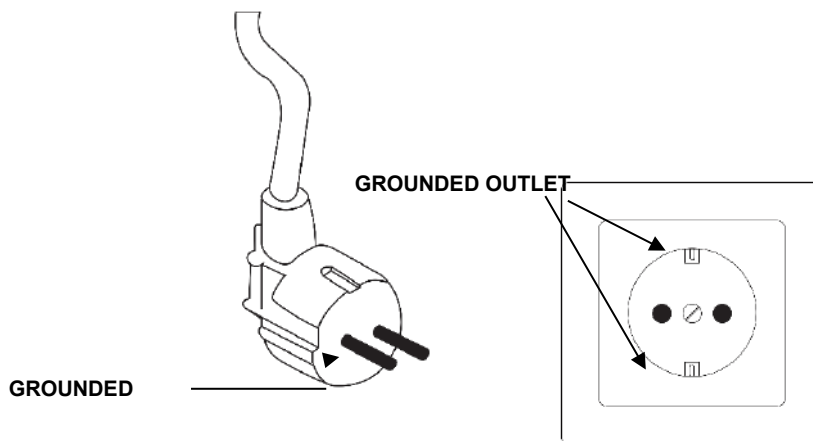

**THE WARRANTY IS NOT VALID IF:** The machine is placed outdoors or exposed to sun and dust. Dust and fluff enter the internal mechanical parts of the machine, causing serious damage. Keep the machine free of dust and fluff.

## ASSEMBLY INSTRUCTIONS

OPEN THE BOX YOU CAN FIND THE ALL PARTS AS BELOW

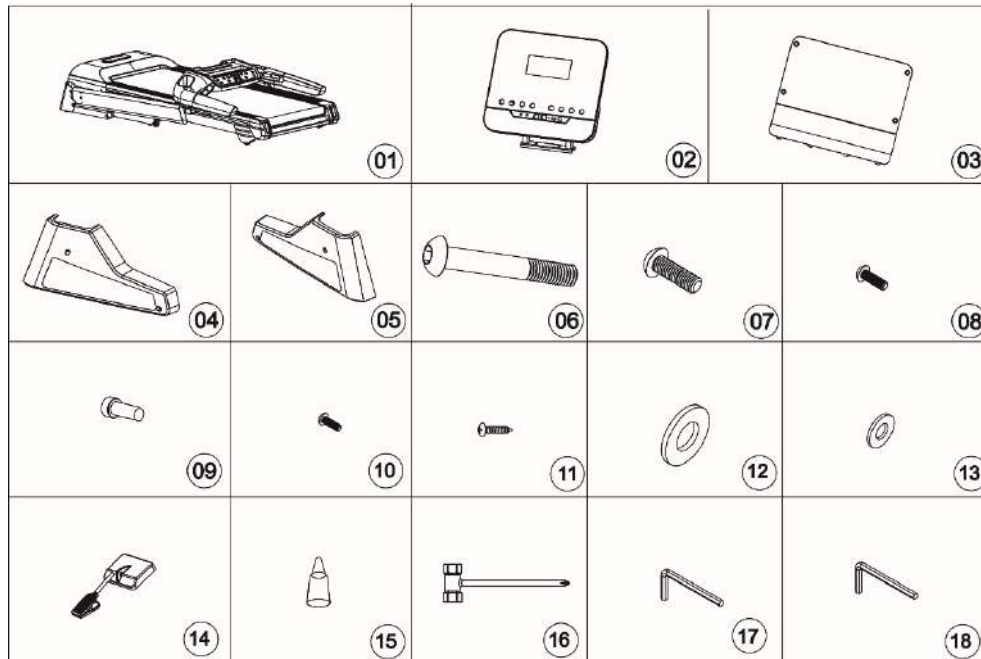

### Part list

No.	Description	Quantity	No.	Description	Quantity
1	Main Frame	1	10	Bolt M5*12	4
2	Computer	1	11	Screw M4*10	4
3	Connection cover	1	12	Washer M10	6
4	Left Side cover	1	13	Washer M8	4
5	Right side cover	1	14	Safety Key	1
6	Bolt M10*55	2	15	Silicon oil	1
7	Bolt M10*20	4	16	Screw Driver	1
8	Bolt M8*15	2	17	Allen wrench 5mm	1
9	Round head bolt M8*15	2	18	Allen wrench 6mm	1

Check and tighten the screws at regular intervals, as they may loosen due to vibrations. Damage that may be caused by a lack of maintenance is not covered by the warranty.

## ASSEMBLY INSTRUCTIONS

**Note:** Assembly requires 2 people.

### STEP 1

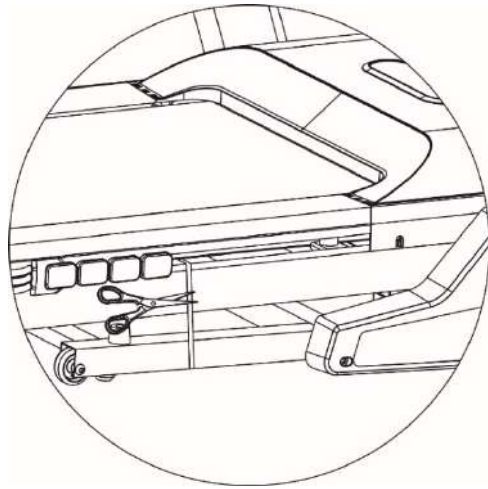

1. Please note that this treadmill need at least 2 people to finish assembly.
2. Open the carton box and take out all the protection foam and assembly parts.
3. As the photo shows, take out the running deck from the box, lay it on the flat floor, and then cut the belt.

**! DANGER!**

Do not cut the belt before moving it out from carton, failure to do so could result in body injury.

### STEP 2

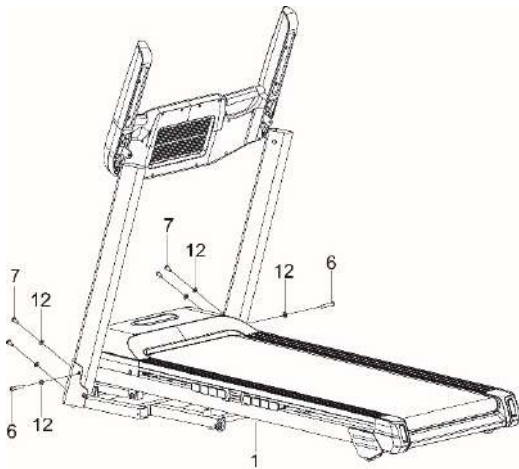

1. Lift up the left and right upright with the console, and then use the 6# wrench (18) to install each upright onto base with 2 pcs M10x55 bolt (6) and 2 pcs flat washer (12), 2 pcs M10x20 bolt (7) and 2 pcs M10 washers (12) on the other side.
2. Do not tightly fasten all the bolts and screws at this step.

### STEP 3

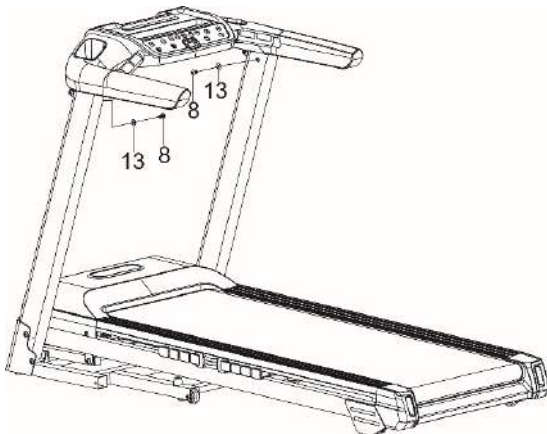

1. Connect the cable extent from console with the cable extent from right upright. Pay attention to the connection of the cable, a wrong connection or rough operation would cause damage of the connector
2. Use the 5# wrench (17) to install the console to the left and right upright with each 2 pcs M8x15 bolts (8) and 2pcs M8 washers (13)
3. Tightly fasten all the bolts at step 2 and step 3

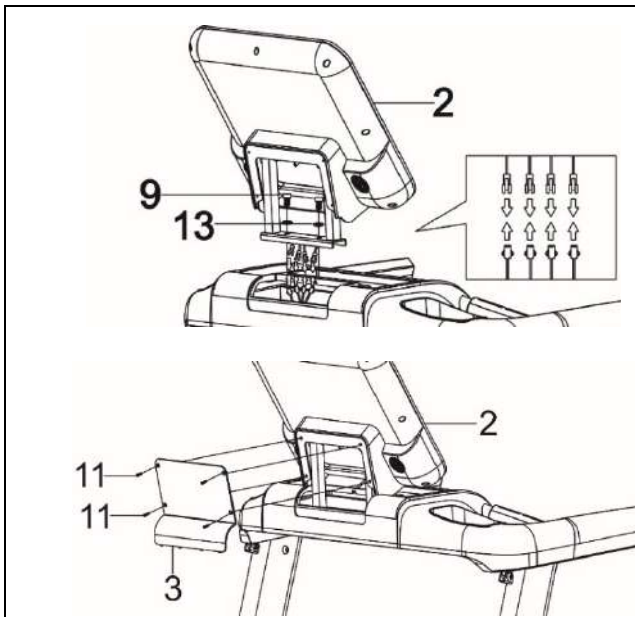
**ASSEMBLY INSTRUCTIONS****STEP 4**

1. Use the 6# wrench (17) to install the computer onto console with 2 pcs round head M8x15 bolts and 2 pcs M8 washer.

2. Connect the cable extent from console with the cable extent from computer. Pay attention to the connection of the cable, a wrong connection or rough operation would cause damage of the connector.

3. Use the screwdriver (16) to install connection cover onto console.

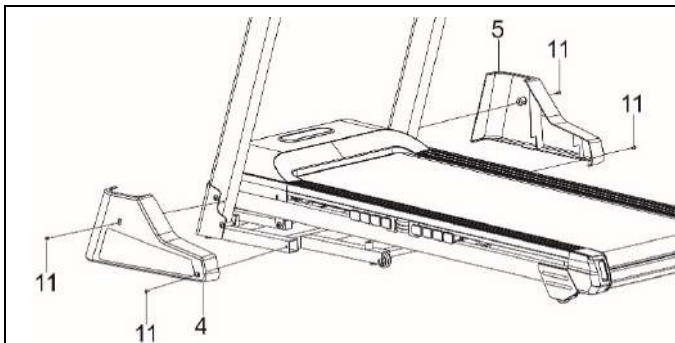
**STEP 5**

Use the screwdriver (16) to install the left base cover (4) to the left upright with 2 pcs M5x12 bolts (10). Do the same for right base cover (5).





## OPERATION GUIDE

### GENERAL SAFETY TIPS

- A.** Practice mounting and dismounting your treadmill before beginning your workout.
- B.** Attach the Safety Key to the Computer (the treadmill will not operate without the Safety Key). Clip the other end of the Safety Key to your clothing before exercising to ensure the treadmill will stop if the user accidentally walks off the Treadmill.
- C.** If the user falls off the Treadmill, the Safety Key will come off the computer and the treadmill will stop at once to avoid further injury.
- D.** Do not stand on the Walking Belt while starting the Treadmill. Straddle the Belt and stand on the plastic Foot Rails.
- E.** The Treadmill will start at 1.0km/h after countdown. If you are a new user, stay at a slow speed and hold onto the Hand Grips until you become comfortable.

### QUICK REFERENCE GUIDE



### DISPLAY FUNCTION

**TIME:** Accumulates total workout time from 0:00 to 99:00 minutes.

**PULSE:** When pulse signal is detected by grasping both stainless steel pick-ups on front handrails, it will display your current heart rate in beats per minute from 50 to 200..

**INCLINE:** Displays the current deck incline from starting at level 1 to 15.

**SPEED:** Displays the current belt speed from starting at 1.0Km/h to 16.0Km/h.

**CALORIE:** Accumulates calorie consumption during exercise. Max. Value is 990 KCAL.

**DISTANCE:** Accumulates total workout distance from 0.0 to 99.0 kilometers by count-up.

Accumulates total workout distance from 0.0 to 99.0 kilometers by count-down.

## GETTING STARTED

### NOTES:

1. Check to make sure nothing is on or will hinder the movement of the treadmill.
2. Plug in the power cord and turn the treadmill ON.
3. Stand on the foot rails of the treadmill.
4. Attach the safety key clip to part of your clothing.

**IMPORTANT:** The SAFETY KEY has a magnet which is connected to the console. At the other end there is a clip that must be placed on your clothes. The treadmill only works with the safety key on the console.

5. Put the safety key into the safety keyhole in the console, and then the treadmill will be on start/ready status.
6. You have two options to start your workout:

### A. QUICK START

Simply press the START button to begin working out.

### B. SELECT A PROGRAM

Select manual program by pressing MODE button or pressing PROGRAM buttons to enter manual program, 8 training goals or 3 user programs.

## QUICK-START OPERATION

**STEP 1:** Attach the Safety key to wake display up; the treadmill then will be on start/ready status.

**STEP 2:** Press the START button to begin belt movement after count-down. Use the SPEED +/- or QUICK SPEED buttons to adjust the desired speed at any time during training; use the INCLINE +/- or QUICK INCLINE buttons to adjust the incline at any time during training.

**STEP 3:** To get a pulse reading, simply grasp stainless steel pick-ups on handrails. It may take a few seconds for the display to reach the actual number. The pulse rate will be displayed on PULSE window.

**STEP 4:** During quick-start operation, TIME, CALORIE and DISTANCE will count up.

## MANUAL PROGRAMS OPERATION

**NOTES:** Under this program, one of DISTANCE, CALORIE and TIME can be set count-down for your workout, the others will count up during your workout, after one count-down reach zero, program will be ended and stop the belt movement, if you need to continue, press the START button to begin belt movement after count-down.

**STEP 1:** Attach the Safety key to wake display up; the treadmill then will be on start/ready status.

**STEP 2:** Press MODE button, the TIME window will display 30:00, press SPEED +/- button to set count-down TIME from 5:00 minutes to 99:00 minutes.

If you do not like to set TIME for count-down and pass to others, press MODE again, the DIST window will display 1.0, you can set count-down DISTANCE from 1.0KM - 99.0KM.

If you do not like to set DISTANCE for count-down and pass to others, press MODE again, the CAL. window will display 50, you can set count-down CALORIE from 20 KCAL to 990 KCAL.

**STEP 3:** After finishing setting count-down for your workout, press START to begin belt movement after count-down.

## OPERATION GUIDE

**STEP 4:** During the program you can adjust the speed and incline by pressing SPEED +/- and INCLINE +/- buttons, or QUICK SPEED and QUICK INCLINE buttons to jump directly to a setting.

**STEP 5:** Press STOP button to stop your workout or pull safety key away from its position to shut down the computer.

### PRESET PROGRAMS OPERATION

#### NOTES:

**All the preset programs are made up with 18 time-based segments; the speed and incline are preset on each segment. The elapse time of 18 segments on each program will be automatically arranged according to the time you set for your workout time. There are 64 preset programs for 8 different training goals, and 8 different intensity levels on each training goals.**

**STEP 1:** Attach the Safety key to wake display up; the treadmill then will be on start/ready status.

**STEP 2:** Press PROGRAM button to scroll through the 8 training goals, and BODY FAT function. A training goal will be selected once you press PROGRAM button. After selecting a training goal, press MODE button to select a intensity from L1 to L8. After selecting a intensity, then press SPEED +/- buttons to modify the elapsing time. The pre-set elapsing time of each program is 30:00 minutes, and it can be set from 5:00 to 99:00 minutes.

**STEP 3:** After modifying the elapsing time, press START button to accept and begin your workout.

**STEP 4:** During procession of program, you can adjust the SPEED & INCLINE by pressing SPEED +/- and INCLINE +/- buttons, or use QUICK SPEED and QUICK INCLINE buttons to jump directly to a setting. However, the SPEED and INCLINE you adjust will only be effective on the ongoing segment, after the segment finished, the SPEED and INCLINE will process with preset values.

**STEP 5:** Press STOP button to stop your workout or pull safety key away from its position to shut down the computer.

### USING THE PULSE FUNCTION

The PULSE Window on your Computer works in conjunction with the Pulse Sensors on both handrails. When you are ready to read your pulse:

1. Place both hands firmly on the Pulse Sensors. For the most accurate reading, it is important to use both hands.
2. Your estimated heart rate will display in the PULSE window approximately 5 seconds after you hold the Pulse Sensors.
3. This estimate is not exact and persons with medical conditions and/or a specific need for accurate heart rate monitoring should not rely on the estimations provided.

**CAUTION!** The heart rate sensor and calorie counter are not medical devices. Several factors can affect the accuracy of the indications. The heart rate sensor is only intended as an aid during exercise to monitor your heart rate in general.

## USER PROGRAM

This program is for user to edit a personal program; the speed and incline of each segment can be edited according as personal's desire. There are 18 segments on this program for user to edit workout program.

Once the program is set, it will be stored on the computer, the computer will proceed the program by pressing START/STOP button. There are totally 3 user programs can be edited.

If you want to re-edit the program, just follow the steps described as bellow.

**STEP 1:** Attach the Safety key to wake display up; the treadmill then will be on start/ready status, keep pressing PROG button until the speed window display U-1, then the TIME window display 30:00, press SPEED+/- to set the program time.

**STEP 2:** Press MODE button to set segment 1, press INCLINE+/- to set incline and press SPEED+/- to set speed on this segment. After finish setting segment 1, press MODE button to set all other 2-18 segments.

**STEP 3:** After finish setting all 18 segments, the program will be stored, and then press START button to load this program.

## USING THE AUDIO FUNCTION

As the figure shows, plug one end of the audio cable to the audio jack on computer, and then plug the other end of the audio cable to MP3 player. The speaker on the computer will then play the music from MP3 player. The volume of speaker can only be adjusted by MP3 player.

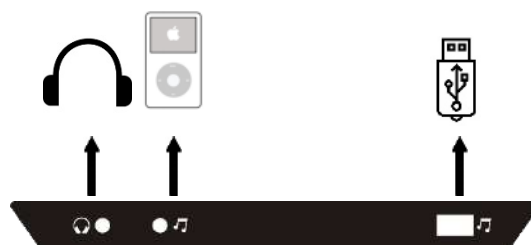

## BUILD-IN MP3 PLAYER

The computer has built-in MP3 player function, it can be operated with following instruction:

Turn on the power of treadmill, attach the Safety key to wake display up, and then plug-in USB flash, then the build-in MP3 player will play the music file in the flash.

## CONNECT SMART PHONE

If the treadmill has the bluetooth function, then connect the smart phone as follow steps:

**STEP1:** Turn on the Bluetooth of the smart phone, search the device, and click to connect the devices when RUN MUSIC appears.

**STEP2:** After the connection, the voice of smart phone will be played by the speaker on the computer.

## OPERATION GUIDE

### BODY FAT SCALE

This function is to estimate your body fat according to the basic information of your body condition.

**This estimate is not exact and persons with medical conditions and/or a specific need for accurate body fat value should not rely on the estimations provided.**

**STEP 1:** Press PROGRAM button repeatedly, on the "11" time pressing PROGRAM button, the TIME window will display FAT. Press MODE button to set the relative parameters: GENDER, AGE, HEIGHT and WEIGHT.

**STEP 2:** After entering BODY FAT function by pressing MODE button, the INCLINE window will display F1, the DIST window will display 1, it represents GENDER, press SPEED +/- button to set gender from 1 - 2, 1 represents MALE, 2 represents FEMALE. Then press MODE button to go to next step.

**STEP 3:** After pressing MODE button, the INCLINE window will display F2, the DIST window will display 25, it represents AGE, press SPEED +/- button to set age from 10-99. Then press MODE button to go to next step.

**STEP 4:** After pressing MODE button, the INCLINE window will display F3, the DIST window will display 170, it represents HEIGHT, press SPEED +/- button to set height from 100CM-220CM. Then press MODE button to go to next step.

**STEP 5:** After pressing MODE button, the INCLINE window will display F4, the DIST window will display 70, it represents WEIGHT, press SPEED +/- button to set weight from 20KG-150KG. Then press MODE button to go to next step.

**STEP 6:** After finished setting all the necessary information of your body condition, press MODE button again, the INCLINE window will then display F5, the DIST window will display "--", it means the computer start to work for calculating, then hold the pulse sensor on handrail with both of your hands, around 8 seconds after, the body fat result will be displayed on INCLINE window.

### BODY FAT CHART

The result that given by body fat scale can be a reference of body condition, check your body condition according to the left chart with the result you get from the treadmill.

Body condition	Result
Fat	BMI > 30
Overweight	26 < BMI < 30
Fit	19 < BMI < 25
Thin	BMI < 19

**CAUTION!** During exercise, heavy sweating can cause mechanical and electrical damage to the machine. Like any other liquid substance, sweat can cause damage mainly to the electrical parts of the machine (dial, cables, etc.). The best solution is to use a towel during exercise and wipe the machine after each use to avoid any unwanted damage.

## PRESET PROGRAM CHART

## P1. WEIGHT LOST

SPEED CHANGES		1	2	3	4	5	6	7	8	9	10	11	12	13	14	15	16	17	18
Level 1	SPEED(KM/H)	1	2	2	3	3	3	4	5	6	6	7	6	5	4	4	3	2	2
Level 2	SPEED(KM/H)	1	2	2	3	4	4	5	6	8	8	10	8	8	5	5	3	2	2
Level 3	SPEED(KM/H)	1	2	3	4	5	5	6	8	9	10	12	10	8	7	6	4	3	2
Level 4	SPEED(KM/H)	1	2	3	4	6	7	8	10	11	12	13	11	10	8	7	5	4	2
Level 5	SPEED(KM/H)	2	3	4	5	7	7	8	10	12	14	14	13	12	10	9	6	4	2
Level 6	SPEED(KM/H)	2	3	4	5	7	9	10	12	13	14	14	13	12	10	9	6	5	3
Level 7	SPEED(KM/H)	2	3	5	6	8	9	10	12	13	14	15	13	12	10	9	6	6	3
Level 8	SPEED(KM/H)	2	3	5	6	8	10	12	14	14	15	15	14	13	11	9	7	6	3

## P2. CARDIO TRAIN

SPEED & INCLINE CHANGES		1	2	3	4	5	6	7	8	9	10	11	12	13	14	15	16	17	18
Level 1	ELEVATION	1	1	2	3	4	5	6	7	7	8	8	7	7	5	4	2	1	1
	SPEED(KM/H)	1	1	2	2	3	4	5	6	6	7	7	6	6	4	3	2	1	1
Level 2	ELEVATION	1	2	3	4	5	6	7	8	8	9	9	8	8	6	5	3	2	1
	SPEED(KM/H)	1	2	2	3	4	5	6	7	7	8	8	7	7	5	4	2	2	1
Level 3	ELEVATION	1	2	4	5	6	7	8	9	9	10	10	9	9	7	6	4	2	1
	SPEED(KM/H)	1	2	3	4	5	6	7	8	8	9	9	8	8	6	5	3	2	1
Level 4	ELEVATION	2	3	5	6	7	8	9	10	10	11	11	10	10	8	7	5	3	2
	SPEED(KM/H)	2	2	4	5	6	7	8	9	9	10	10	9	9	7	6	4	2	2
Level 5	ELEVATION	2	4	6	7	8	9	10	11	11	12	12	11	11	9	8	6	4	2
	SPEED(KM/H)	2	3	5	6	7	8	9	10	10	11	11	10	10	8	7	5	3	2
Level 6	ELEVATION	3	5	7	8	9	10	11	12	12	13	13	12	12	10	9	7	5	3
	SPEED(KM/H)	2	4	6	7	8	9	10	11	11	12	12	11	11	9	8	6	4	2
Level 7	ELEVATION	4	6	8	9	10	11	12	13	13	14	14	13	13	11	10	8	6	4
	SPEED(KM/H)	3	5	7	8	9	10	11	12	12	13	13	12	12	10	9	7	5	3
Level 8	ELEVATION	5	7	9	10	11	12	13	14	14	15	15	14	14	12	11	9	7	5
	SPEED(KM/H)	4	6	8	9	10	11	12	13	13	14	14	13	13	11	10	8	6	4

## P4. POWER WALK

SPEED CHANGES		1	2	3	4	5	6	7	8	9	10	11	12	13	14	15	16	17	18
Level 1	SPEED(KM/H)	1	1	2	2	3	3	4	4	4	4	4	4	3	2	2	2	1	1
Level 2	SPEED(KM/H)	1	2	2	2	3	3	4	4	5	4	4	4	3	3	2	2	1	1
Level 3	SPEED(KM/H)	1	2	2	3	3	4	4	5	5	5	4	4	4	3	3	2	1	1
Level 4	SPEED(KM/H)	1	2	3	3	3	4	4	5	6	6	5	4	4	4	3	2	2	1
Level 5	SPEED(KM/H)	1	2	3	4	4	5	5	5	6	6	6	5	4	4	4	3	2	1
Level 6	SPEED(KM/H)	1	2	3	4	5	5	6	6	6	6	6	5	5	4	4	3	2	1
Level 7	SPEED(KM/H)	1	2	3	4	5	6	6	7	7	6	6	6	5	5	4	3	2	1
Level 8	SPEED(KM/H)	1	2	3	4	5	6	7	7	7	7	6	6	6	5	5	4	2	1

## P3. FAT BURN

SPEED & INCLINE CHANGES		1	2	3	4	5	6	7	8	9	10	11	12	13	14	15	16	17	18
Level 1	ELEVATION	1	1	2	2	3	3	4	5	5	5	5	4	4	3	2	2	1	1
	SPEED(KM/H)	1	2	3	3	5	6	7	8	8	8	8	7	7	5	4	3	2	1
Level 2	ELEVATION	1	1	2	2	3	4	5	6	6	6	6	5	5	4	3	2	1	1
	SPEED(KM/H)	1	2	3	4	6	7	8	9	9	9	9	8	8	6	5	3	2	1
Level 3	ELEVATION	1	1	2	3	4	5	6	7	7	7	7	6	6	4	3	2	1	1
	SPEED(KM/H)	1	2	4	5	7	8	9	10	10	10	10	9	9	7	6	4	2	1
Level 4	ELEVATION	1	2	3	4	5	6	7	8	8	8	8	7	7	5	4	3	2	1
	SPEED(KM/H)	2	3	5	6	8	9	10	11	11	11	11	10	10	8	7	5	3	2
Level 5	ELEVATION	1	2	3	4	6	7	8	9	9	9	9	8	8	6	5	3	2	1
	SPEED(KM/H)	2	4	6	7	9	10	11	12	12	12	12	11	11	9	8	6	4	2
Level 6	ELEVATION	2	3	4	5	7	8	9	10	10	10	10	9	9	7	6	4	3	2
	SPEED(KM/H)	3	5	7	8	10	11	12	13	13	13	13	12	12	10	9	7	5	3
Level 7	ELEVATION	2	3	5	6	8	9	10	11	11	11	11	10	10	8	7	5	3	2
	SPEED(KM/H)	4	6	8	9	11	12	13	14	14	14	14	13	13	11	10	8	6	4
Level 8	ELEVATION	2	4	6	7	9	10	11	12	12	12	12	11	11	9	8	6	4	2
	SPEED(KM/H)	4	7	9	10	12	13	14	15	15	15	15	14	14	12	11	9	7	4

## P5. INTERVAL

SPEED CHANGES		1	2	3	4	5	6	7	8	9	10	11	12	13	14	15	16	17	18
Level 1	SPEED(KM/H)	1	2	4	2	4	2	4	2	4	2	4	2	4	2	4	2	4	2
Level 2	SPEED(KM/H)	1	2	5	2	5	2	5	2	5	2	5	2	5	2	5	2	5	2
Level 3	SPEED(KM/H)	1	2	6	2	6	2	6	2	6	2	6	2	6	2	6	2	6	2
Level 4	SPEED(KM/H)	1	3	6	3	6	3	6	3	6	3	6	3	6	3	6	3	6	3
Level 5	SPEED(KM/H)	1	3	7	3	7	3	7	3	7	3	7	3	7	3	7	3	7	3
Level 6	SPEED(KM/H)	2	4	7	4	7	4	7	4	7	4	7	4	7	4	7	4	7	4
Level 7	SPEED(KM/H)	2	4	8	4	8	4	8	4	8	4	8	4	8	4	8	4	8	4
Level 8	SPEED(KM/H)	2	5	8	5	8	5	8	5	8	5	8	5	8	5	8	5	8	5

## P6. ROLLING

SPEED CHANGES		1	2	3	4	5	6	7	8	9	10	11	12	13	14	15	16	17	18
Level 1	SPEED(KM/H)	1	2	3	2	1	2	3	2	1	2	3	2	1	2	3	2	1	1
Level 2	SPEED(KM/H)	2	3	4	3	2	3	4	3	2	3	4	3	2	3	4	3	2	2
Level 3	SPEED(KM/H)	2	3	4	5	4	3	4	5	4	3	4	5	4	3	4	5	4	3
Level 4	SPEED(KM/H)	2	4	5	6	5	4	5	6	5	4	5	6	5	4	5	6	5	3
Level 5	SPEED(KM/H)	2	5	6	7	6	5	6	7	6	5	6	7	6	5	6	7	6	3
Level 6	SPEED(KM/H)	3	6	7	8	7	6	7	8	7	6	7	8	7	6	7	8	7	4
Level 7	SPEED(KM/H)	3	7	8	9	8	7	8	9	8	7	8	9	8	7	8	9	8	4
Level 8	SPEED(KM/H)	3	8	9	10	9	8	9	10	9	8	9	10	9	8	9	10	8	4

## P7. MOUNTAIN CLIMB

SPEED & INCLINE CHANGES		1	2	3	4	5	6	7	8	9	10	11	12	13	14	15	16	17	18
Level 1	ELEVATION	0	1	1	2	2	3	3	4	4	5	6	7	8	7	6	4	2	0
	SPEED(KM/H)	1	1	2	2	3	3	3	4	4	4	3	3	3	2	2	2	1	1
Level 2	ELEVATION	0	1	2	2	3	3	4	4	5	6	7	8	9	8	6	4	2	0
	SPEED(KM/H)	1	1	2	2	3	3	3	4	4	4	3	3	3	2	2	2	1	1
Level 3	ELEVATION	1	1	2	3	3	4	4	5	6	7	8	9	10	9	8	6	4	2
	SPEED(KM/H)	1	1	2	2	3	3	3	4	4	4	3	3	3	2	2	2	1	1
Level 4	ELEVATION	1	2	2	3	3	4	5	6	7	8	9	10	11	10	8	7	5	3
	SPEED(KM/H)	2	2	3	3	4	4	4	5	5	4	4	4	3	3	3	2	2	2
Level 5	ELEVATION	1	2	3	4	5	6	7	8	9	9	10	11	12	11	10	8	6	4
	SPEED(KM/H)	2	2	3	3	4	4	4	5	5	4	4	4	3	3	3	2	2	2
Level 6	ELEVATION	2	2	3	4	5	6	7	8	9	10	11	12	13	12	10	8	6	4
	SPEED(KM/H)	2	2	3	3	4	4	4	5	5	4	4	4	3	3	3	2	2	2
Level 7	ELEVATION	2	3	4	5	6	7	8	9	10	11	12	13	14	13	10	8	6	4
	SPEED(KM/H)	2	2	4	4	5	5	5	6	6	6	5	5	4	4	4	2	2	2
Level 8	ELEVATION	3	4	5	6	7	8	9	10	11	12	13	14	15	13	10	8	6	4
	SPEED(KM/H)	2	2	4	4	5	5	5	6	6	6	5	5	4	4	4	2	2	2

## P8. HILL RUN

SPEED & INCLINE CHANGES		1	2	3	4	5	6	7	8	9	10	11	12	13	14	15	16	17	18
Level 1	ELEVATION	0	0	1	1	2	2	2	3	3	3	4	4	5	5	4	3	2	1
	SPEED(KM/H)	2	2	2	3	3	3	5	5	7	7	9	9	10	8	8	6	4	2
Level 2	ELEVATION	0	0	1	1	2	2	2	3	3	3	4	4	5	6	5	3	2	1
	SPEED(KM/H)	2	2	2	4	4	4	6	6	6	8	8	10	10	8	8	6	4	2
Level 3	ELEVATION	0	0	1	1	2	2	3	3	3	4	4	5	5	6	5	3	2	1
	SPEED(KM/H)	2	2	4	4	4	6	6	6	8	8	10	10	12	10	8	6	4	2
Level 4	ELEVATION	0	1	1	2	2	3	3	4	4	4	5	5	6	7	6	5	3	2
	SPEED(KM/H)	2	2	4	4	6	6	8	8	8	10	10	10	12	12	10	7	5	3
Level 5	ELEVATION	1	1	2	2	3	3	4	4	5	5	6	6	7	8	7	6	3	2
	SPEED(KM/H)	2	4	6	6	6	6	8	8	8	10	10	12	13	12	10	7	5	3
Level 6	ELEVATION	1	2	3	4	4	4	5	5	6	6	7	8	8	8	7	6	3	2
	SPEED(KM/H)	2	4	6	6	6	6	8	8	10	10	12	13	13	12	10	7	5	3
Level 7	ELEVATION	1	2	3	4	5	6	6	7	7	8	8	9	10	10	9	6	3	2
	SPEED(KM/H)	2	4	6	6	8	8	10	10	12	13	13	14	13	12	10	7	5	3
Level 8	ELEVATION	1	2	3	4	6	6	7	7	8	8	9	9	10	12	9	6	3	2
	SPEED(KM/H)	2	4	6	8	10	10	12	12	13	13	14	14	13	12	10	7	5	3



## HOW TO FOLD AND MOVE

### HOW TO FOLD THE TREADMILL

Before folding the treadmill, unplug the power cord. **CAUTION:** You must be able to safely lift 45 pounds (20kg) in order to raise, lower, or move the treadmill.

1. Hold the treadmill with your hands in the locations shown at the right. **CAUTION: To decrease the possibility of injury, bend your legs and keep your back straight. As you raise the treadmill, make sure to lift with your legs rather than your back.** Raise the treadmill until the running deck is firmly held by the folding pole as the right figure shows.

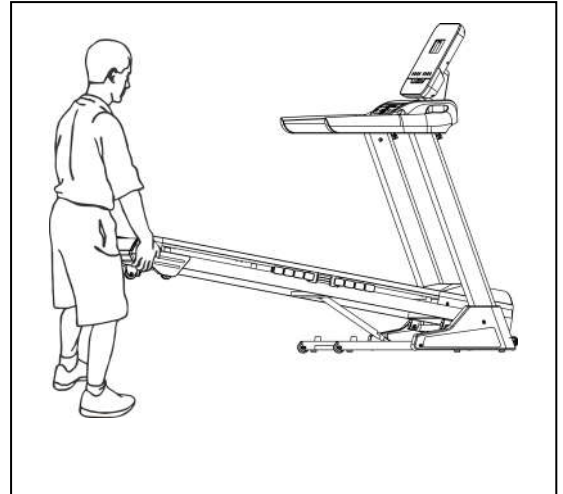

2. If you want to put the treadmill to the work position, Firstly, pull the folding knob outward as figure shows, And then lay down the running deck light onto floor.

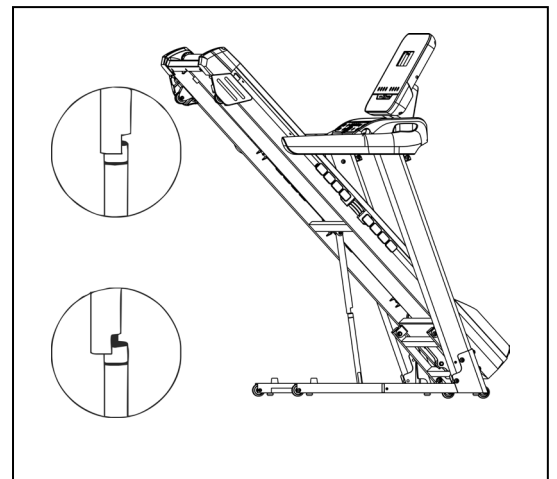

### HOW TO MOVE THE TREADMILL

1. Hold the handrails as shown and place one foot against a wheel.
2. Tilt the treadmill back until it rolls freely on the wheels. Carefully move the treadmill to the desired location.

**Never move the treadmill without tipping it back. To reduce the risk of injury, use extreme caution while moving the treadmill. Do not attempt to move the treadmill over an uneven surface.**

3. Place one foot on a wheel, and carefully lower the treadmill until it is resting in the storage position.



**SUGGESTED STRETCHES**

A successful exercise program consists of a warm-up, aerobic exercise, and a cool-down. Do the entire program at least two and preferably three times a week, resting for a day between workouts. After several months, you can increase your workouts to four or five times per week.

Warming up is an important part of your workout and should begin every session. It prepares your body for more strenuous exercise by heating up and stretching out your muscles, increasing your circulation and pulse rate, and delivering more oxygen to your muscles. At the end of your workout, repeat these exercises to reduce sore muscle problems. We suggest the following warm-up and cool-down exercises:

**1. Inner Thigh Stretch**

Sit with the soles of your feet together with your knees pointing outward. Pull your feet as close into your groin as possible. Gently push your knees towards the floor. Hold for 15 counts.

**2. Hamstring Stretch**

Sit with your right leg extended. Rest the sole of your left foot against your right inner thigh. Stretch toward your toe as far as possible. Hold for 15 counts. Relax and then repeat with left leg extended.

**3. Head Roll**

Rotate your head to the right for one count, feeling the stretch up the left side of your neck. Next, rotate your head back for one count, stretching your chin to the ceiling and letting your mouth open. Rotate your head to the left for one count, and finally, drop your head to your chest for one count.



## SUGGESTED STRETCHES

### 4. Shoulder Lift

Lift your right shoulder up toward your ear for one count. Then lift your left shoulder up for one count as you lower your right shoulder.



### 5. Toe Touch

Slowly bend forward from your waist, letting your back and shoulders relax as you stretch toward your toes.

Reach down as far as you can and hold for 15 counts.



### 6. Calf-Achilles Stretch

Lean against a wall with your left leg in front of the right and your arms forward. Keep your right leg straight and the left foot on the floor; then bend the left leg and lean forward by moving your hips toward the wall. Hold, and then repeat on the other side for 15 counts.



### 7. Side Stretch

Open your arms to the side and continue lifting them until they are over your head.

Reach your right arm as far upward toward

the ceiling as you can for one count.

Feel the stretch up your right side.

Repeat this action with your left arm.

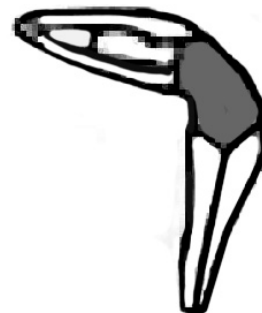

**WARNING!** Always unplug the power cord before performing any maintenance on your treadmill.

**CLEANING:** Regular cleaning of your treadmill will extend its life.

**WARNING!** To avoid electric shock, make sure the treadmill is off and the power cord is unplugged before cleaning or maintenance.

**AFTER EVERY EXERCISE:** Wipe the console and other surfaces of the treadmill with a clean, dry soft cloth to remove excess sweat. **DO NOT USE CHEMICALLY.**

**WEEKLY:** The use of a machine protective floor or mat is recommended for ease cleaning. The dirt from the shoes comes in contact with the moving belt and eventually penetrates the bottom. The use of a vacuum cleaner under the treadmill is recommended once a week.

**MONTHLY:** put a broom under the treadmill to prevent dirt or trash from accumulating. Once a year, you should remove the black cap of the motor and clean the dirt that may have accumulated in this area.

**WOODEN PLATFORM LUBRICATION:** Periodic lubrication control of the belt is recommended to ensure the optimal performance of the treadmill. Every 1 month, or 20 - 40 hours of operation, lift the ends of the drive belt and touch the top of the wooden platform as far as your hand can reach. If you feel traces of silicone, you do not need lubrication. If you feel the wooden surface is dry, you need lubrication. Ask your seller or call the technical department for the type of silicone.

#### HOW TO LUBRICATE PLATFORM

**Caution:** Get the right product for lubricating the drive belt. Do not use grease or anti-rust liquid or any other spray.

1. Put the spray nozzle on the lubrication spray head.
2. While lifting the drive belt on one side, place the spray nozzle between the drive belt and the wooden platform about 10cm from the front of the treadmill. Apply the silicone spray to the wooden platform, moving back and forth. Repeat for the other side of the drive belt. Spray for about 4 seconds on each side.
3. Run the treadmill for 2 minutes at a speed of 5 km / h so that the silicone is spread over the entire wooden surface and then you can use the treadmill normally.

**WARNING:** Do not over-lubricate the wooden platform. Excess lubricant should be wiped with a clean towel.

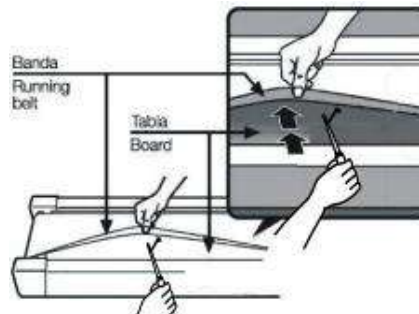

**WARNING:** The friction of the platform with the treadmill plays an important role in the operation and life of the treadmill and for this reason we recommend that you keep the treadmill clean and frequently lubricate this point of friction to extend the life of the treadmill. If you do not follow the above, the validity of the guarantee ceases.

## Running belt tension adjustment

The treadmill has been adjusted and passed QC inspection before leaving the factory. If there is phenomenon of bias running of the belt, the possible reasons might be:

- A. The frame is not stably laid
- B. The user is not running on the center of the running belt.
- C. The user's two feet are not using even strength.

For bias which cannot be fixed automatically, try the following methods to fix the belt, as picture shown

If the belt tends to move to the right, you should turn the belt adjustment screw on the right in clockwise direction. We recommend you turn 1/4 turn each time and check how it works. If the belt remains slanting to the right, then turn the belt adjustment screw on the left in counterclockwise direction 1/4, as shown in the picture A

If the belt tends to move to the left, then turn the belt adjustment screw on the left in clockwise direction for 1/4 turn. If the belt remains slanting to the left, then turn the belt adjustment screw on the right in counterclockwise direction for 1/4 turn, as shown in the picture B

After having been used for a period, the belt might be slightly elongated, and slipping and halting might appear when a person is running on it. When these phenomena appear, you should secure the screws on both sides for 1/4 turn. If the belt is too tight, just loosen the screw on both sides for 1/4 turn, as shown in picture C

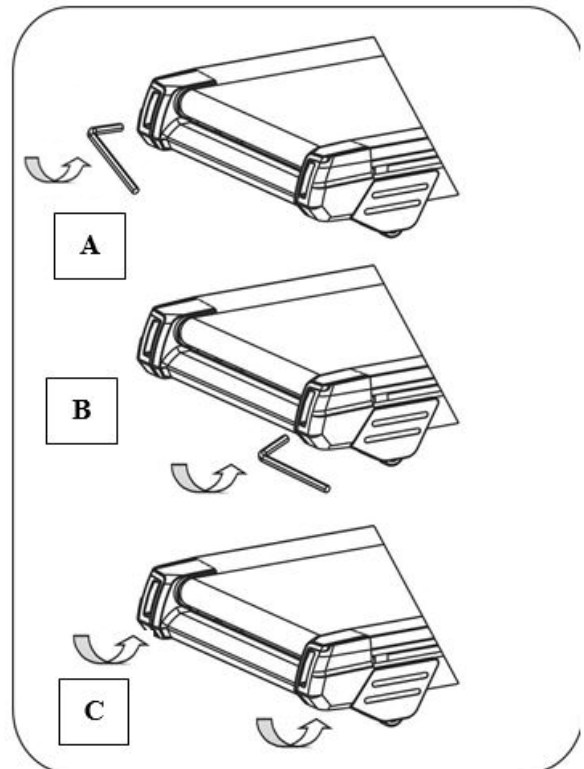

**CAUTION!** The use of a protective carpet (plastic carpet or thin carpet) under the fitness machine is considered essential for its proper use, avoidance of vibrations and protection of the floor. The company does not bear any responsibility for causing damage due to misuse of the product and non-compliance with the instructions for use.



EXPLODED DRAWING

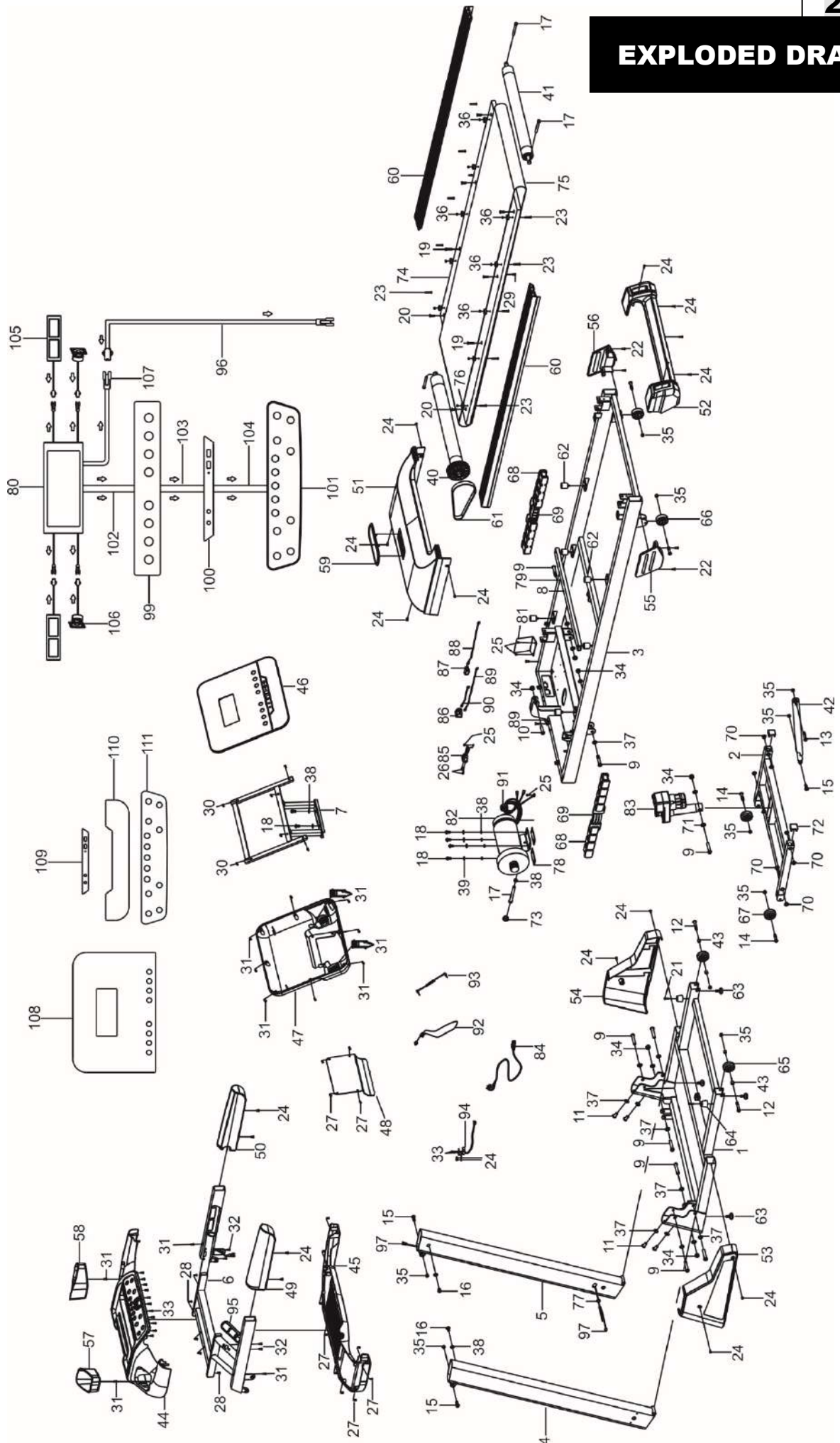

**PART LIST**

No.	DESCRIPTION	Qty
1	Base frame	1
2	Incline rack	1
3	Main frame	1
4	Left upright	1
5	Right upright	1
6	Console rack	1
7	Computer rack	1
8	Support tube	1
9	Bolt M10*55	9
10	Bolt M10*40mm	1
11	Bolt M10*20mm	4
12	Bolt M8*50mm	2
13	Bolt M8*45mm	1
14	Bolt M8*40mm	4
15	Bolt M8*28mm	3
16	Bolt M8*15mm	2
17	Bolt M8*65mm	4
18	Bolt M8*15mm	6
19	Bolt M6*40mm	2
20	Bolt M6*25mm	6
21	Screw M6*20mm	2
22	Screw M6*10mm	4
23	Screw M5*28mm	10
24	Screw M5*12mm	17
25	Screw M4*12mm	7
26	Screw M4*15mm	2
27	Screw M4*12mm	22
28	Screw M4*40mm	4
29	Screw M4*25mm	2
30	Screw M4*20mm	6
31	Screw M4*10mm	16
32	Screw M3.5*25mm	4
33	Screw M3*6mm	14
34	Nut M10	6
35	Nut M8	10
36	Bolt M5	10

No.	DESCRIPTION	Qty
37	Flat washer	16
38	Flat washer	9
39	Spring washer	4
40	Front roller	1
41	Rear roller	1
42	Cylinder	1
43	Transport wheel cap	4
44	Console upper cover	1
45	Console lower cover	1
46	Computer upper cover	1
47	Computer rare cover	1
48	Connection cover	1
49	Left handrail foam	1
50	Right handrail foam	1
51	Motor cover	1
52	Rear end cap	1
53	Left base cover	1
54	Right base cover	1
55	Left wheel cover	1
56	Right wheel cover	1
57	Left bottle holder	1
58	Right bottle holder	1
59	Brand sticker holder	1
60	Side rail	2
61	Motor belt	1
62	Deck cushion	6
63	Leveling foot	4
64	Base support cushion	2
65	Base moving wheel	2
66	Support wheel	2
67	Incline rack moving wheel	2
68	Air cushion	4
69	Spring Cushion	2
70	Incline rack plastic bushing	8
71	Incline motor plastic bushing	2
72	Tube cap	2

**PART LIST**

73	Tube cap	1	93	Audio cable	1
74	Running board	1	94	Speed sensor	1
75	Running belt	1	95	Handrail pulse	2
76	Side rail fastener	10	96	Console cable	1
77	Cable grommet	1	97	Upright cable	1
78	Motor rubber cushion	2	98	Cable clip	1
79	Support tube cushion	1	99	Quick key PCB	1
80	Computer PCB	1	100	Audio jack PCB	1
81	Controller	1	101	Keypad PCB	1
82	DC Motor	1	102	Quick key cable	1
83	Incline motor	1	103	Audio cable	1
84	Power code	1	104	Keypad cable	1
85	Power code jack	1	105	Pulse sensor	1
86	Power switch	1	106	Speaker	1
87	Overload protector	1	107	Computer cable	1
88	AC cable-red	1	108	Display layout 1	1
89	AC cable-black	1	109	Audio jack layout	1
90	AC cable-brown	1	100	Display layout 2	1
91	Magnetic ring	1	101	Keypad layout	1
92	Safety key	1			

**SPECIFICATIONS**

<b>Motor:</b>	DC 3.5 hp	<b>Incline range:</b>	15 levels
<b>Speed range:</b>	1.0 - 20.0 km/h	<b>Weight:</b>	90 kg
<b>Belt surface:</b>	140 x 51 cm	<b>Maximum user weight:</b>	125 kg
<b>Platform thickness:</b>	1.8 cm	<b>Dimensions (open):</b>	180 x 160 x 88 cm
<b>Display:</b>	7 Led fields	<b>Dimensions (closed):</b>	120 x 160 x 88cm
<b>Certifications:</b>	CE-ROHS-EN957	<b>Storage system:</b>	Easy lift system
		<b>Anti-vibration system:</b>	AirShox, 14 elastomer points
<b>Programs:</b>	64 built-in programs, Body fat, Manual		
<b>Display Indications:</b>	Time, speed, incline, distance, calories, program / user program, body fat		
<b>Other:</b>	High quality sound system, MP3 player, USB port		



**TROUBLE SHOOTING**

<b>PROBLEM</b>	<b>POSSIBLE CAUSES</b>	<b>CORRECTION</b>
Console has no display	<ol style="list-style-type: none"> <li>1. Power cord not plugged well.</li> <li>2. Defection on whole set cable or not plug well.</li> <li>3. Overload protection.</li> </ol>	<ol style="list-style-type: none"> <li>1. Check power cord connection.</li> <li>2. Plug every connector well.</li> <li>3. Reset overload protector.</li> </ol>
Treadmill belt slipping	<ol style="list-style-type: none"> <li>1. Running belt too loose.</li> <li>2. Motor belt too loose.</li> </ol>	<ol style="list-style-type: none"> <li>1. Tighten running belt.</li> <li>2. Tighten motor belt.</li> </ol>
Running belt not smooth	<ol style="list-style-type: none"> <li>1. Lack lubrication oil</li> <li>2. Running belt too tight.</li> </ol>	<ol style="list-style-type: none"> <li>1. Add lubrication oil to belt and deck.</li> <li>2. Loose running belt.</li> </ol>
Motor does not work	<ol style="list-style-type: none"> <li>1. Safety key not attached correctly.</li> <li>2. Motor cable does not connect well.</li> <li>3. Whole set cable does not plug well.</li> <li>4. Controller damaged.</li> <li>5. Motor damaged.</li> </ol>	<ol style="list-style-type: none"> <li>1. Insert safety key.</li> <li>2. Check motor cable connection.</li> <li>3. Plug whole set cable again.</li> <li>4. Replace controller.</li> <li>5. Replace motor.</li> </ol>

### **TERMS OF WARRANTY**

- Warranty period is 5 years for motor, 2 years for electrical / electronic parts and 5 years for the metal frame.
- X-TREME STORES S.A. undertakes to repair the machine free of charge in the event of damage due solely to a manufacturing fault. The warranty covers the cost of the spare parts. Replacement of spare parts or not is up to the company technicians. The customer is responsible for the control and adjustment of the machine.
- This warranty note is only valid if it is accompanied by legal proof of purchase (invoice or retail receipt). The warranty period is not extended for any reason and the transfer of it to a third party is excluded.
- Any damage is repaired as soon as possible and any claim for damages due to lack of spare parts and delay in repairing the damage is excluded. The costs of transporting the machine to or from the dealership will be borne by the customer after 6 months of purchase.
- The warranty conditions are set by the manufacturers of machinery and are governed by European regulations.
- Upon expiry of the warranty, any replacement part is covered by a 6-month warranty.

### **THE WARRANTY SHALL NOT APPLY:**

- When the machine is used for any purpose other than home use (gyms, clubs, institutes, hotels, studios, etc.).
- When the fault is the result of misuse, alterations, poor connection, poor maintenance, voltage fluctuations in the PPC network.
- Components damaged by user fault such as broken plastic parts, damaged belt with improper adjustment, incorrect or incomplete lubrication, damage when moving the machine.
- Components such as side pads and cushions are considered consumables and are covered by a 6-month warranty.
- When the machine is opened or repaired by third parties.
- When the damage is caused by the buyer's negligence & the instructions for use have not been followed.
- When the machine is outdoors or exposed to sun or dust. (Dust and lint on the inside of the machine (motor roller) cause serious damage. Keep the machine clean!).
- When electronic components (console) are damaged by intense sweating or other liquid that has come into contact with or penetrated inside them.

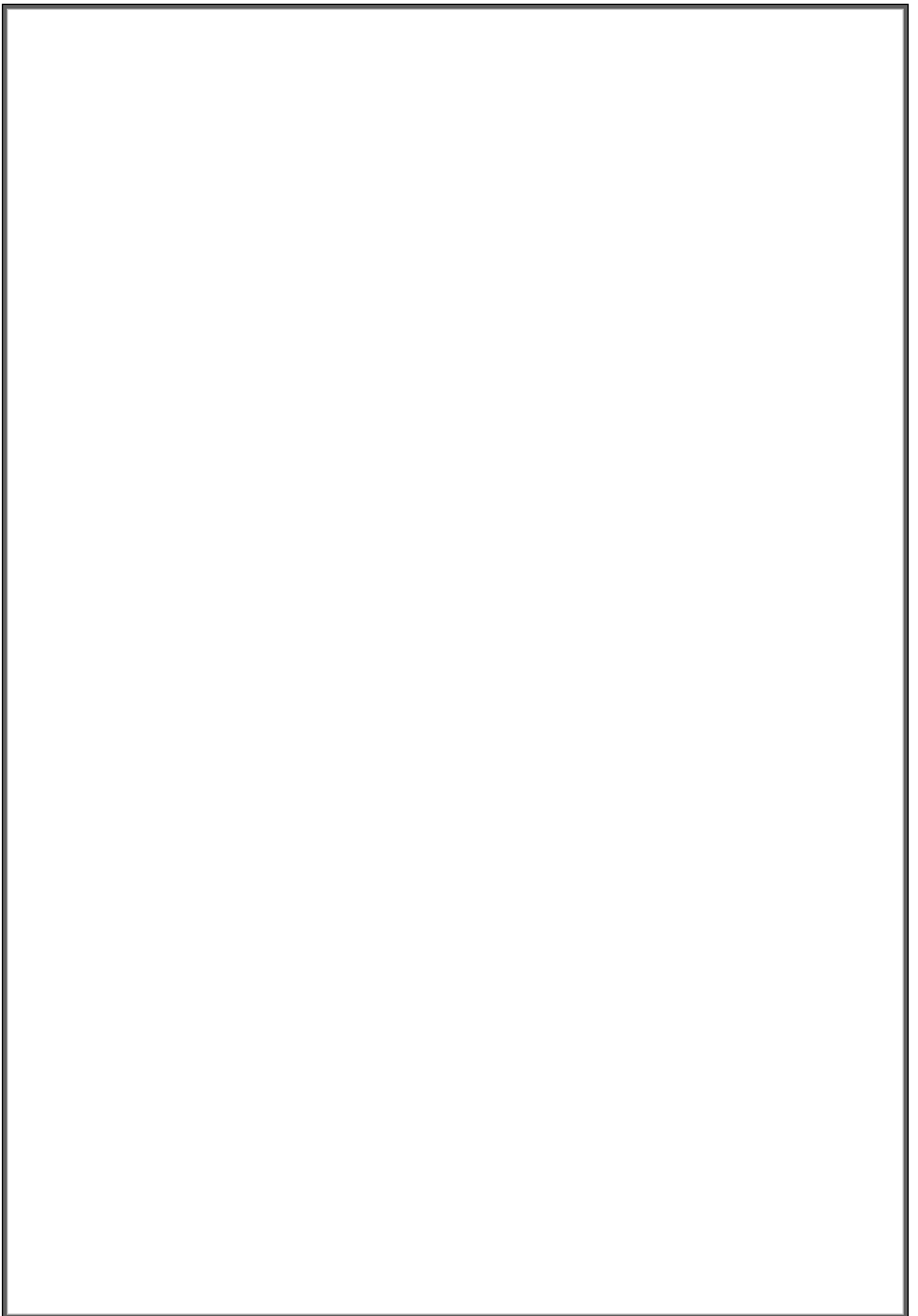



Koupi Avenue 34, Koropi P.C. 19441 P.O.Box 6201

**Tel.:** 210 66 20 921 -2 - **FAX:** 210 66 20 923

**E-mail:** [info@xtr.gr](mailto:info@xtr.gr) • [f/xtrstores](https://www.facebook.com/xtrstores) •  [/@xtr.gr](https://www.instagram.com/xtr.gr)

**Tel for all Greece:**

**801.11.15.100**

**[www.xtr.gr](http://www.xtr.gr)**